



Overseas Scholarship to U.S.A.

May 1998

Fire Prevention programs and strategies for
homes caring for the deinstitutionalised.

**Roy Marshall
Leading Firefighter
Community Safety
Metropolitan Fire & Emergency Services Board**

614.841.3-001.83
MAR



CONTENTS & INDEX

Executive Summary	3
Background	4

Recommendations	7
------------------------------	---

Phoenix Fire Department-Arizona	9
Major Contacts.....	20
National Fire Protection Association	21
Seattle Fire Department	28
Major Contacts.....	32
San Francisco Fire Department	33
Major Contacts.....	33
Los Angeles City Fire Department	34
Major Contacts.....	37
Appendix 1	38
Appendix 2 & 3	39
Appendix 4	40

99-0401

Executive Summary:

Introduction:

I would like to thank the Emergency Services Foundation for their generous support in allowing me to undertake this study tour to the United States. I would also like to thank the Metropolitan Fire & Emergency Services Board and in particular the Chief Executive Officer Mr. Bob Solly and the Director Fire & Hazard Safety Mr. Neil Bibby for providing some valuable leads in the U.S.

The aim of the study trip was to investigate what fire safety /prevention programs if any emergency services provide to occupants who had been de-institutionalised. The cities chosen for this study tour were:

Date	Fire Department	Contact
May 9th – 16th	Phoenix Arizona	Barbara Koffron
May 16th – 21st	N.F.P.A. Conference	
May 21st - June 1st	Seattle, Washington	Charity Burns
June 1st – 3rd	San Francisco	Fernando Juarez
June 3rd – 7th	Los Angeles	.Alan Masumato

I also took the opportunity whilst in the U.S. to attend the National Fire Protection Association's annual meeting in Cincinnati Ohio. This annual meeting attracts guest speakers from all over the world.

Background:

Emergency services are increasingly taking on an expanded role in the services they provide to the community.

As they take on these evolving roles, already limited resources are stretched even further.

The closure of large institutions/training centres in Australia has been under way since the 1970's. In Victoria we are in the forefront of this process as reported in the Department of Human Services Annual Reports.

The process of de-institutionalisation has resulted in large numbers of people being integrated back into the community in suburban housing. The organisations responsible for their welfare are increasingly seeking the assistance from emergency services to make these homes as safe as possible for both clients and staff.

No emergency service should underestimate the impact this process will have on their organisation.

The community based housing concept will require all Fire Services, Police, State Emergency Service and the Ambulance Service to become involved at some stage with these organisations and their houses.

The Metropolitan Fire & Emergency Services Board is receiving an increasing number of requests for assistance in formulating emergency procedures for these community-based homes. They have also been involved in developing fire safety and emergency procedure training packages for staff and their clients who have been moved from an institutionalised environment back into the wider community.

Metropolitan Fire & Emergency Services Board has noted that there has been an increase requesting assistance from organisations assist people with a

mental illness or substance abuse housed in boarding house type accommodation.

The study tour I will undertake will be looking at:

1. ***Programs on fire safety in community based housing.***
2. ***Processes that are in place to identify these types of housing.***
3. ***Any inter agency agreements regarding staff training.***
4. ***Methods utilised to deliver any programs.***

After visiting and working with the above listed Fire Services and talking to a number of Government agencies and individuals it became apparent that in the U.S. the de- institutionalisation process is not as wide spread as it is in Victoria. Most of the people who had been placed back into the wider community were either capable of functioning at a greater level of independence than is found in Victoria eg most were able bodied and capable of going to the local shopping centre. Of those that required a greater level of care and supervision family members generally cared for them.

The community based homes that I did encounter were predomantly for people that had disabilities relating to vision, hearing, or mental illness.

The de-institutionalisation process in San Francisco was confined mainly to the mental health area similar to what has been occurring in Victoria for the past number of years.

None of the Fire Services that I visited had any comprehensive program that addressed people that had come from a de-institulised situation into the wider community. What processes were in place were mainly aimed at ensuring that houses had portable fire extinguishers, evacuation guidelines and earthquake

recovery and procedures. Earthquake procedures were of greater concern in California than any other state.

When some form of state or local licence was required even though the licence was renewed each year very little time was spent ensuring that staff were adequately trained. In many instances staff informed me that the inspecting authority spent little time assessing staff capabilities and or training in relation to their procedures. Most often an inspection of plans and equipment was all that was done.

When a copy of the self-paced training package that has been developed by the Metropolitan Fire & Emergency Board were shown to Fire Services, Government Agencies or direct care staff they said this program was exactly what they had been looking for to train staff and develop emergency procedures. Even organisations that cared for clients that did not fall exactly into the category of intellectually disabled were of the opinion that the package could be adapted to suit their needs.

Fire Services in the main liked the concept of the program being self-paced as this required little man hours to be from their departments but still allowed them to make contact with these houses when they were established in their jurisdiction.

In the State of Washington the state Governor has set up a task force to investigate Fire Protection Co-ordination for the Washington State. Eric Robertson who heads this task force was impressed with the program we had in place and requested a copy to be presented at the next meeting of this task force. A similar request was received from Deputy State Fire Marshal Les Townzend for Washington State.

In summary I believe that the fire safety/prevention programs and strategies that the Metropolitan Fire & Emergency Board are currently in place or being developed are far ahead of any that I saw on this study tour. We are ahead of Fire Services in being pro active and innovative in the way we deliver fire

safety training and programs for the public. I also believe that we are far more responsive to the requirements from organisations and groups in the community.

Recommendations:

I have the following recommendations for consideration. Most of these recommendations relate to current programs and the methods used in developing and presenting these programs.

- *The Metropolitan Fire & Emergency Services Board establish links with the various Federal, State, Local Government Departments that are responsible for the care of people with a physical/mental disability. To ensure a uniformed approach to fire safety/prevention in this type of accommodation.*
- *The same links be established with non-government organisation providing similar accommodation.*
- *A network of personnel from all agencies that may be involved in an emergency situation with this type of housing be formed to look at establishing a uniformed approach and exchange of information regarding this type of housing.*
- *All ethnic peak bodies be contacted to ascertain if they are operating this type of housing,*
- *Training for all staff working in this type of housing undergo emergency procedure and portable fire extinguisher operation as part of their induction for new care workers.*
- *All existing care workers currently working undergo similar training as part of ongoing skills maintenance.*

1

Phoenix Fire Department

9th May – 16th May

Fire Safety Department

Arrived at airport and was met by Captain. Guy of Phoenix Fire Department and taken to Station 24 where I will be staying. All of the day departments were shut for the weekend (it being Mothers Day) I had to wait until after the weekend to speak to their Public Education Department, Fire Prevention Departments and Department of Housing.

It was interesting to note that all crews were aware that they needed to be of value to their community and saw many of the tasks they do as an extension of their normal job routine.

After speaking with the station crews it appeared that the City of Phoenix did not have any CRU type housing like those in Melbourne. Many families attended to the care of relatives with intellectual disabilities at home due to the high cost of having them in private residential care. The city has some very large retirement homes and community type homes for the aged and senior citizens.

All public and commercial high rise buildings have evacuation procedures as do high rise residential housing. There was no compulsion to for there to be mandatory drills.

10th May 1998

Attended a number of calls all EMS. Visited 25 Station met Battalion Chief Richard Wolfe who invited me to attend the Battalion Chiefs deployment meeting the following day and discuss the issue.

11th May 1998

Today visited various departments at HQ and central district.

The Phoenix Fire Department Administration Office is located in the centre of town. We also visited the departments communication centre, and administrative areas. It was interesting to note that whilst visiting the HQ that disabled refuge signs were prominently displayed throughout the complex. Refuge areas had been added to Fire Department HQ to enable people with a disability problem to utilise these areas in the event of an emergency. All areas were fitted with an intercom and lights to allow also occupants to communicate with or be contacted by the Fire Department during an emergency and make them aware of their presence in a refuge area.

Attended the deployment meeting at HQ it was interesting to see management and workers sharing in the process of deployment of equipment and manpower. Each respected the various views on a range of subjects presented at the table Deputy Chief and the Assistant President of the Local IAFF shared the Co-chair. Also attending the meeting were support staff who were encouraged to have input. I was asked join in the discussions at any time I wished. It was an interesting management/union working arrangement. This working arrangement was considered to be the best labour management set up as far as Phoenix Fire Department was concerned. At this meeting I spoke to a number of Battalion Chiefs to ascertain their awareness of people with a disability who lived in Community Residential Unit (CRU) style accommodation. None were aware of any such CRU's in their areas. The predominant means of housing for people with an intellectual disability was with family members or in some cases in small private style accommodation that had no more than 2 or 3 people in care. In nearly all cases the number of

people in the houses was kept below a figure where they became subject to State or Federal regulations.

Spoke to the following people at Urban Safety:

Joe Bushong Public Education Phoenix Fire Department

We spoke about various programs that are delivered by the Metropolitan Fire & Emergency Services Board. He was interested in the “Be cool when it’s hot” CD. He explained that the PFD were looking at developing a similar program in the future and believed that the MFESB was well ahead of many departments in the USA in actually having a program up and running in such a format. After viewing the CD he said that he could see where it could be utilised in the Phoenix Fire Department Juvenile Fire Setters Program, I left him a copy for them to use as a reference and aid to developing their program. I asked him about the any programs being used by PFD for the disabled and was told that most of the programs were aimed at the elderly or supported residential units which were primarily elderly nursing homes. He believed that a program for the disabled was up and running about 2 years ago and would endeavour to obtain information on the program. We discussed various other programs they were running such as injury and medical prevention. These have become big issues for Phoenix Fire Department and are the main areas Joe was working in. The use of many local and state sporting identities to promote safety via posters etc was heavily used by the department.

Donna M. McCloe Administrative Aide Urban Services

Donna was responsible for the administration of the Phoenix Fire Department, Senior’s Outreach Program (copy of program obtained). This program is designed to provide fire safety information to senior’s citizens living in high rise residencies. No specific strategies were in place for people with disabilities in these buildings. Phoenix Fire Department had developed a program titled

“Senior Outreach Program - Fire & Life Safety for Seniors,” which had just been printed and was being prepared for implementation. The program was being delivered by various means utilising both Phoenix Fire Department day staff and volunteers from organisations that interact with senior citizens.

Donna also said that they were unaware of any CRU type dwellings that existed in the Phoenix area but believed that they may exist. Many homes existed in the area that catered to elderly in SRS (Supported Residential Services) type homes. Many of the SRS type homes escaped any code enforcement regulations except for the basic's such as Smoke Alarms due to the residential homes housing no more than 6 people. The Phoenix Fire Department is only notified of some of these SRS home when they apply for state registration. We discussed the CRU program that is being run in Melbourne. Donna expressed great interest in obtaining a copy of the full program this will be photocopied in Phoenix and a copy of the video will be sent to her upon return to Melbourne. She was especially interested in the self-paced learning aspect of the program and its acceptance by the Department of Human Services in Melbourne. I will also talk to Carol Gross at Urban Services who also runs similar type programs to Donna's.

Barbara Koffron Assistant to Chief Brunacini

Barbara is the assistant to Chief Brunacini of the Phoenix Fire Department and as such is very well informed about the programs that are run by the Urban Services Division. She said that the Phoenix Fire Department had not been involved with any CRU type housing in the Phoenix or surrounding counties but would investigate the matter. The main type of housing where it involved people with any sort of disability was with the elderly in residential type housing. The main concern regarding this type of housing was that they were not identified in any way for the fire department and upon arrival at a residence where these people are housed they are confronted with the major evacuation of all residents. Within the Phoenix Fire Department area they also had many residents with alcohol and substance abuse problems that are housed in local residential housing but again there was no requirement to

notify the fire department of these premises. We spoke about various types of programs that the Metropolitan Fire & Emergency Services Board deliver. Barbara was interested in learning more about the Fire Safety Self-Paced Program for CRU's. When we meet again on Friday she requested that I bring a copy along for her and Ed Manning to look at, as she believed that it might have a use with in the Phoenix Fire Department. She would also like have a copy of the Fire Ed CD-ROM. Barbara concluded our meeting by saying:

"I'm was very impressed with what you are doing in the Fire Prevention/Public Education sector and you are well ahead of the Phoenix Fire Department and indeed most Fire departments in the U.S.A. in this area".

12 May 1998

Dina Beck Community Worker Seniors

In the evening I spoke to Dina Beck Community Worker Human Services Department City of Phoenix. Dina works with senior citizens and expressed interest in the Metropolitan Fire & Emergency Services Board Retire Ed concept and how it was delivered. She was aware of CRU type homes in Phoenix but was not sure as to their status or any requirements for staff training. She will attempt to use her contacts to ascertain if there any requirements for staff training in CRU type homes. I will be visiting her workplace Urban League Manor to see a couple of innovations that are in place which connect seniors with teenagers via the Internet. The seniors become like grandparents to many children who may want have an adult to talk to. Possible Contact Ph. (602) 262 1609 Fax. (602) 534 4000

13th May 1998

This morning was taken up with attending combined Fire Chiefs meeting and simulation exercise at the Training Academy. The meeting was held with chiefs of surrounding cities and involved discussion on any issues that had occurred since the last meeting then followed a simulation exercise. The experience was interesting to watch and observe.

Richard Beardsley City of Phoenix - Housing Department

Spoke to Richard who said that the answer to my questions were not that simple as the various types of clients were covered by different departments. There were houses that were similar to CRU's they consisted in the main of home based care, group home and family homes. As to the question of staff training he was unsure but suggested that I contact Valinda Mores at Department of Health Services to ascertain if training is mandatory and what type of training is undertaken. Most clients who live in these types of housing would be classified as people requiring continual supervision as many had mild mental and physical disabilities and care was generally in the day to day running of the household.

Valinda B. Mores Arizona Department of Health Services

Valinda is responsible for program management of Children's Services in Arizona. She was aware of Group Homes being in the Phoenix and surrounding areas. Although she did not have any control over group homes she believed that the State Fire Marshal's Office would be able to assist me as **some** group homes require a licence to operate and this office issued such licences.

Ruddy Karel & John Fiorentino State Fire Marshal's Office

I went to the office of the State Fire Marshal, as both these people are responsible for issuing the licences for Group Homes. Upon arrival at their office I was informed that they were both out of town until the end of the week (17/05/98) and I would be unable to talk to either of them, as I will be leaving Phoenix on the 16/05/98. Fortunately whilst at the office I was introduced to Yolonda Contreras from the Arizona Department of Health Services.

Yolonda Contreras Special Licensure Inspector

Yolanda works out of the same building as the Arizona State Fire Marshals in Phoenix. She works in the area of checking for compliance with each home having plans, escape routes, fire prevention strategies and portable firefighting equipment. She was able to assist me with the checklists she uses when visiting each home. On completion of these forms they are forwarded to the correct sections of the Health Department for records maintenance. The homes are classified into two groups each requiring differing levels of equipment.

I was given the name of David Matthews who also worked for the Department of Economic Security and may be able to assist me.

David Matthews Department of Economic Security.

I spoke to David at his office and after explaining my area of study he said that the best person to speak to was Jim Anderson from Developmental Disabilities Disorders in the Department of Economic Security as he was responsible for Co-ordination of group home accommodation. David contacted Jim and a meeting was arranged for the following day at Jim Anderson's office.

Jim Anderson Department of Economic Security Division of
Developmental Disabilities (DDD)

The process of moving people from an institution back into the community has been going on for the last 15 years, the process is still going on, that moving people from an institution now includes the mental health areas, and this will need to be addressed in the near future.

Jim explained that there were no formal training programs in place with the Phoenix Fire Department but he would like to see some training formally put into place to ensure that training would be uniform and reflect Phoenix Fire Department standards.

All premises that are classified, as Home & Community Based Service (HCBS) provider must under go a Biennial Life/Fire Safety Inspection (see appendix1). This inspection focuses on a number of requirements that service provider must provide. There were a number of anomalies in these requirements such as not having to have a displayed emergency evacuation floor plan if the residence has less than seven residents.

Jim also pointed out the fact that even though Portable Fire Extinguishers are required to be in place and staff know how to operate them he was not aware of any training to test staffs competency in the use of extinguishers or fire blankets.

If a mobile home was used as a HCBS then an inspection was conducted annually.

Many people operating homes catering for people with mental /physical disabilities kept client numbers to 2 to 3 this way they avoided being classified as a business and not subject to HCBS requirements. This was a problem that the department was aware of but had little or no ability to police. Also many ethnic groups within the community tended to avoid using government or private agencies for two reasons, in the private sector cost was the major reason and in the government many of the people were either illegal immigrants or unaware of places available due to language problems. This

created an illegal market that had grown over the years and involved people from a number of ethnic backgrounds.

After viewing the program that had been developed with Metropolitan Fire & Emergency Services Board and Department of Human Services in Victoria he requested that a copy so that it could be evaluated by his department. They were looking at establishing a training program for carers and what he had just viewed would be exactly what they were looking for and with suitable modifications may be able to used as a bases for their HCBS's.

Again it appeared that we were well ahead in addressing clients needs in this area.

15th May 1998

Barbara Koffron Assistant to Chief Brunacini.

Spoke once again to Barbara Koffron regarding some of the programs that we deliver to various groups within the Melbourne community.

I raised the question of if the Phoenix Fire Department were looking at training/educating care givers in the community who look after group homes in fire safety. Barbara said that they would be talking with Jim Anderson as soon as it was possible.

The concept of providing the services that are provided in Melbourne by Community Safety to various industries is alien to the Phoenix Fire Department. They believe that no company or government agency would be willing to pay for this service nor do they believe that they have the work force to deliver the service.

Many of their programs are delivered by volunteers trained by the department. Some of the Phoenix Fire Department fire safety programs are delivered by on shift firefighters particularly those that require Spanish language to be spoken.

We also spoke about the Retire Ed program in which retired members of the fire department are utilised to deliver fire safety lectures to seniors.

She was also interested in the way we packaged our resource materials in categories for ease of distribution.

Barbara requested that we send her copies of some of the programs that we deliver to various sections of the community,

Ed Manning Senior Inspector Phoenix Fire Department

Ed has been an Inspector with the fire department for the past 40 years.

He was interested in the self-paced training concept and would most definitely arrange a meeting with Jim Anderson to talk about the Department of Economic Security requirements in fire safety training.

Ed was unaware of the number of Group Homes that were located in the City of Phoenix. He was aware of the problems that handicapped people faced that were cared for at home and when ever the department became aware of such homes it was usually via local stations attending for a medical call at the home.

It was not a general routine thing for Group Homes to be added to the alarm dispatch system. This system automatically notifies the dispatcher when the street address is typed that the address has occupants with a disability living there.

This system would be have advantages for the fire service in Australia to adopt. As most of the information is readily available via the D of HS or its equivilent counter parts interstate.

Most fire safety/prevention programs were aimed at the senior citizens and aged care facilities with in Phoenix and surrounding areas

Most fire safety/prevention programs were aimed at the senior citizens and aged care facilities with in Phoenix and surrounding areas

Carol Gross Urban Services Department

Carol is responsible for the design and delivery of program's for the Elderly and Juvenile Fire Setters.

Once again Carol confirmed that the issue of training of staff in Group Homes had never been addressed as this area had never been fully identified as needing attention. She was most interested in the program that we were running and had a copy I had with me copied to read at a later date.

Carol believed that to deliver a program such as ours via on shift personnel be they firefighters or Community Safety staff would be impossible due to the following reasons:

- Not enough staff in the system
- Fee for service concept untested

Major Contacts Arizona:

Cassie Peters

Assistant Fire Chief
Phoenix Fire Department
150 South 12th Street
Phoenix Arizona
85034 2301
(602) 262 7775
(602) 534 1374 Fax

Jim Anderson

Life Safety Specialist
Arizona Department of
Economic Security
1789 West Jefferson
PO Box 6123, Site Code 791A
Phoenix Arizona
USA 85005
(602) 542 6794

Barbara Koffron

Phoenix Fire Department
150 South 12th Street
Phoenix Arizona
85034 2301

Joe Bushong

Phoenix Fire Department
150 South 12th Street
Phoenix Arizona
85034 2301

Carol Gross

Phoenix Fire Department
150 South 12th Street

Phoenix Arizona.

Richard Beardsley

City of Phoenix Housing
Department
251 West
Washington Street
Phoenix Arizona
USA 85005
(602) 261 8035

Donna Mcloe

Urban Services Division
Phoenix Fire Department
150 South 12th Street
Phoenix Arizona
85034 2301
(602) 534 9834

Dina Beck

Urban League Manor
4343 West Thomas Road
Phoenix Arizona
USA 85035
(602) 262 1609
(602) 534 4000 Fax

Ed Manning

Phoenix Fire Department
150 South 12th Street
Phoenix Arizona
85034 2301

National Fire Protection Association

Annual Meeting & Fire Safety Exhibition

Cincinnati, Ohio 17th May – 21st May

Overall Impression

The overall impression of the conference was that it was worthwhile to see in my case the different perspective and importance that Fire Prevention receives. The networking that can be done makes attending this conference extremely worthwhile. Many diverse views are put forward and debated along with in most cases excellent speakers from fire services, industry and government.

Whilst most of the technical aspect may be aimed at the North American area many of these in some way shape or form have some connection with similar legislation back in Australia. The main area of concern for me was the fact that in many cases building code requirements could be subject to local requirements and code inspectors satisfaction. The fact that there is no national building codes for the USA is quite surprising. In this light Australia is a long way ahead of the USA with our building code legislation.

Window bar legislation.

This session was one that was lively debated. The N.F.P.A. and the U.S. Government are actively tackling this problem of window bars being fitted to premises. A number of families have been killed due to the fitment of these bars which cut of a second means egress in an emergency.

The problem is twofold the first being that the window bars provide security to householders in lower socio-economic groups and in most instances the level of knowledge on fire safety and prevention issues within this socio-economic group is very poor.

A number of programs have been implemented to tackle this problem. One is a proposed requirement that the bars must contain wording that explains the dangers of fitting window bars that do not have an opening device that can be easily activated from the inside of the house.

Most of the window bars fitted to houses are of the fixed type and are installed by a local handy man. It was felt that the safety warnings would have little or no impact the installers only concern was to make a sale and the safety warning would not be passed onto the householder.

One other concern raised was the fact that many of the window bars that were fitted to houses were of the do it yourself variety this was particularly evident in rental housing where in many cases the owner would install the bars without any regard for the residents.

In nearly all states it would require a building permit to install the window bars but it was the opinion of the speakers and audience present that this was almost universally ignored. One city in Florida had attempted to enforce the removal of the bars where it impeded the only alternative exits from a dwelling. This had proved to be a very time consuming.

Another scheme has begun that would appear to be having a very good success rate. This has involved a large insurance company supporting a program of removing fixed window bars and having opening type ones fitted. This has been funded via Federal Grants and support (the insurance company has assisted via printing materials and company staff donating their time). An unusual problem that has arisen from this program has been the reluctance of residents who are eligible to receive funding not wanting or refusing it due to previous experiences that have involved them receiving grants and at a later date they were asked to repay the grants. Also as the Hispanic community

has many illegal immigrants they are very reluctant to become involved in programs where they may be identified as being illegal immigrants and subsequently deported.

The Hispanic community also perceives the window bars as a decorative addition to their homes as this is quite the normal addition to homes. And as such they have brought this custom with them to the U.S.

The same problems relative to security concerns prevail within the African-American and Asian communities.

It was interesting to note that many ethnic firefighters had formed groups to address this problem from their own particular cultural viewpoint. They believed that they were best equipped to tackle the problem and culturally they could reach these groups that a general campaign would not. Departments also utilized firefighters from different ethnic backgrounds to reach out to all the differing ethnic groups in the community.

During the open forum on this one audience member spoke about his installed belief that it was not necessary to have window bars fitted that opened easily. He fitted window bars as part of his business. He had designed some bars that had a simple locking device (a pin type) that was simply removed whenever someone was in the house. Upon leaving the pin was placed in the locked position, he did not believe that people would leave the window locked when they were inside. An assumption on his part that did not escape those in attendance. He also stated that the removal of these bars in an emergency situation was not a difficult task he even showed every one present the key that would remove the bars in such a situation. A crowbar! To finally conclude his pro window bar stance he stated that he had been a firefighter for 15 years and had always been able to remove bars from a window very quickly and easily. He had conveniently forgot the very young, elderly, and the fact that it would take quite some time for the average person to pry these bars from a window.

Speakers:

Salvador Morales, President National Assoc. Hispanic Firefighters, Dallas Texas.

Oshiyemi Adelabu, President Inter. Assoc. Black Professional Firefighters, Milwaukee Wisconsin.
Howard Hooper, Supervisor Codes & Tech. Services U.L. Inc. Santa Clara, California.
Guy Fraker, Agency Field Executive, State Farm Insurance, Oakland, California.
Steve Kastner, Fire Marshal, Fort Lauderdale Fire Rescue, Fort Lauderdale ,Florida.
Bill Middlemiss, Massachusetts State Fire Marshal's Office, Stowe Massachusetts.

Not only egress but ingress.

This session was well attended as the subject was of interest to many attending the conference. The main thrust of the session was two incidents that had taken place in Cincinnati in recent years these being a rock concert by the British group The Who and the Supperland Nightclub fire. Both incidents involved the movement of large crowds.

The rock concert incident dealt with inward movement of a large group of people and the Supperland Nightclub with the exiting of a large crowd.

The question raised at this session was that the movement of people both in and out of a building should be given far more emphasis when considering evacuation strategies.

ADA Safe Havens.

This session was more of an information session run by David Thompson of the Cornell Communications Inc. It was a very good session to attend, as this area will be one of increasing importance within Australia.

Cornell Communications manufacture signalling and communication systems for the disabled. They had on show in the exhibitor's hall many of their devices that are fitted within buildings for use by the disabled in Safe Havens. Many of their products are multi functional in that they can be used by mobility, visually and hearing impaired.

A number of diagrams illustrating examples of safe havens for the disabled were also obtained from David Thompson. David will also be sending a

catalogue of the equipment that Cornell Communications manufacture for use in safe havens.

The products that were on display had various ways for people with a disability to be communicated with as well as for them to communicate with arriving fire personnel and make their where location known.

It will be interesting upon return to Australia to ascertain if there are any Australian companies producing similar products for the disabled.

Currently there is thought being given to utilising safe havens not only for people with a disability but by people that are either trapped or have a medical condition that may preclude them from evacuating the premises in an emergency. (see appendix 2 & 3)

Risk Watch.

Mari-K Appy spoke about the NFPA's latest safety program for school children Risk Watch.

This is a comprehensive safety program for school age children grades prep to 9. It covers not only fire safety but also a number of areas such as water safety, pedestrian and car safety. The program is slowly being adopted by many states in the US and Canada. Some problems have been encountered where schools and fire departments are not willing to adopt the program due to the already heavy curriculum commitments in schools and a number of fire departments believe that the cost of the program is too high. Appy said that the NFPA were trying to overcome this small problem area by saying that a certain portion of the school curriculum must address health and safety issues and that this would be the ideal program as it is fully developed and tested.

Change from suppression to prevention.

At the various seminars and speaker sessions I attended it was very noticeable *that there was a small percentage of fire departments now*

beginning to focus their attention to prevention rather than suppression.

This change is in the minority as most people that I spoke to held the traditional view that Fire Prevention/Public Education was for young children or the senior citizens.

This view is in direct contrast to here in Australia where Fire Prevention is given a much higher profile and emphasis. The difference was brought home to me in a talk that was given by Wayne Morris Association of America. During his talk the subject of kitchen fires was raised the information offered to householders was do not try to extinguish the fire but to immediately evacuate the house and call the fire department. The belief was that the householder would do more harm to himself or herself if they attempted to extinguish the fire They did not recommend that householders install a fire extinguisher or fire blanket. I found this type of information being offered to householders to be inadequate to say the least. Surely if the householder was given the right advise and instructed to read the manufacturers operating instructions before use. Many house fire may be extinguished early thus reducing damage to the house.

Chief Gary Richardson Ottawa Fire Department.

Chief Garry Richardson was one of the more lively and interesting speakers at the NFPA Annual Conference. Chief Richardson is from the Ottawa Fire Department and spoke about how he has changed his fire department from the traditional suppression fire department to one that now actively and vigourously embraces the fire prevention method. His opening comment I believe set the scene “For the first 18 years of my fire service career I fought fires totally wrong I was more interested inputting fires out I should have been more interested in preventing them from happening.”

Chief Richardson put forward a number of ideas and strategies that he was in the process of implementing in his department. Sitting back listening to what he proposed to do seemed quite logical to me as we in the MFESB are doing

most of these things now. Such radical concepts as On Shift Fire Investigators and expanded Fire Prevention/Public Education Departments.

To most of the audience present the ideas and concepts being put forward by Chief Richardson were coming from left field as far as they were concerned.

Also allows the staff at Fire Prevention/Public Education to work flexible hours. His rationale for this was that they are required at different times of the day to perform functions. Chief Richardson put forward the premise what difference did it make if they worked 2 hours one day and 12 hours the next so long as the customers were being serviced and staff were available when required.

3

Seattle Fire Department

Washington

21st May to 31st May

Public Education

The first 3 days in Seattle coincided with the U.S.A. Memorial Day and all day departments of the Seattle Fire Department's were closed, as were all Government Departments.

The City of Seattle was similar to Phoenix in that the fire services did not have any specific data on CRU within their jurisdiction. They were aware that some housing for people with a disability existed but these were mainly housing for people with mild intellectual disabilities or were more for people with a psychiatric problem that had been de-institutionalised.

Community Residential Unit type housing was a very hot issue in Seattle now as more people being placed back into the wider community.

There was no specific training that involved the Seattle Fire Department training staff from these homes.

Training was provided for occupants of High Rise apartments but again the issues of people with physical and mental disabilities were not addressed.

26th May 1998

Spoke to following people:

Steve Nelson City of Seattle Fire Marshal

Steve was most helpful when the question of CRU housing was first raised, he stated that this was a very hot topic currently in Seattle. There were no formal programs for training staff who worked in this type of facility. He requested that the department's legal representative be able to sit in on our meeting and discuss our program.

Both said that with the move to place people back into housing rather than institutions it was a timely visit.

After viewing the program Steve said he believed that we were way ahead of the Seattle Fire Department in formulating this type of Fire safety program and all US fire departments save for one or two. The only other State that may have a program similar to ours was Oregon but he added that the State Fire Marshal's and the fire departments there had suffered large budget cuts that may have curtailed the proposed program. He suggested that I contact them and see where their program was at.

Steve liked the concept of the program being developed in partnership with the Health Departments and delivered by the fire department. The fact that the program was designed to be administered by the Health department was another aspect that made it easier to implement.

The fact that once again the fire department would find the delivery aspect a problem. This appeared to be a common problem with various fire departments.

Steve expressed his concern that most fire departments in the US placed more effort and resources into the suppression area. Fire Safety/Prevention

staffing in fire departments was in nearly all cases minimal and staff was trying to cover large client bases with limited resources.

They were more code enforcement style geared but all present agreed that the prevention community safety route was the way to be heading.

I was advised that I should contact Eric Robertson who was the Fire Protection Co-ordinator State Governors Commission on Fire safety.

Eric Robertson Fire Protection Co- Ordinator State Governors Commission

I could only speak to on the telephone as he was due to leave for Washington DC that day. I explained what I was in Seattle for and the program that we had developed in Australia. He was very interested in obtaining a copy for appraisal as he said it was one of the areas he was attempting to formulate Statewide. He asked me to make a copy available to him if this was possible and to speak with Les Townzen Deputy Chief State Fire Marshal

27th May 1998

Charity Burns Fire Safety Department

Charity is head of the Seattle Fire Departments Fire Safety Division she was also unaware of any requirement for training for CRU style homes in fact she was unaware of any homes that were in the Seattle.

After viewing and discussing the program in place in Victoria she said that he could have an application in Seattle with suitable modifications. The areas that she had in mind were for people who had suffered mild brain damage and lived in housing catering for such people. These homes were small in client numbers and the clients were capable of undertaking most tasks unassisted such as going shopping but required some supervision in the running of the household eg paying bills etc.

A number of topics were discussed with Charity and Carol Lo during my time in Seattle both work in the Fire Prevention area and were very interested in how we produced and delivered programs. They were of the opinion that we were far ahead of anything that they had come across in the US. In particular they wish to pursue the possibility of having a version of the CD Rom titled "Be cool when it's Hot" produced for the US market.

29th May 1998

Les Towenzen Deputy Sate Fire Marshal

Les was very keen for me to present the package that we had developed for Department of Human Services on CRU's to a sub committee that he chaired looking at this very issue. The meeting was to take place on 5th June 1998 unfortunately I had to be in Los Angeles by this time and expressed my regret at not being able to present this package.

I went through the package and strategy behind in it for Les so he could clearly have and understanding of it this would enable him to present the details to the meeting in the 5th and answer any questions that may arise.

The package was well received by Les and he said that it was well-presented and easy to use. He particularly like the idea of a video being used as part of the training package as it was not always possible to demonstrate the use of fire extinguishers in some areas but this would enable staff to do a refresher type training quite easily.

He would also like to be kept informed of any other packages that we may develop for similar type accommodation in the future. He said that the main client base that was of a concern to them right now was people who had be removed from institutions dealing with mental disabilities. Many of these

Major Contacts Washington:

Steve Nelson

City Fire Marshall
Seattle Fire Department
301 Second Avenue South
Seattle, WA 98104
USA
(206) 386 1339

Eric Robertson

Fire Protection Co-Ordinator
State Governors Committee
(360) 753 0360

Charity Burns

Seattle Fire Department
301 Second Avenue South
Seattle, WA 98104
USA
(206) 386 1423

Carol Lo

Seattle Fire Department
301 Second Avenue South
Seattle, WA 98104
USA

Les Towenzen

Deputy Chief State Fire Marshal
PO Box 42600
Olympia
WA 98504 26200
USA
(306) 753 0442

4

San Francisco Fire Department

California

1st June to 3rd June

Bureau of Fire protection

The time spent in San Francisco was very disappointing as their Fire Prevention department consisted of 2 staff and the facilities there were a long way behind us in Australia.

Never the less Fernando Juraz a firefighter assigned to the department assisted in many ways whilst we attempted to see if any homes similar to CRU's were in existence in the city. After visiting many of the government departments and various departments in the Fire service it became clear that most people who had undergone the de-institutionised process were from and mental health area and not from areas like in Victoria.

The main concern for the Fire department concerned these people. Most of the clients were housed in cheap boarding type accommodation or cheap slum type hotels. The people were also largely transient in that they wandered from city area to city area and no accurate record of where these people were housed was available.

Also the pre-occupation within this department seemed to focus at earthquake survival.

Major Contact San Francisco

Fernando Juraz

Bureau of Fire Prevention
San Francisco Fire Department
260 Golden Gate Avenue
San Francisco
CA 94102
USA
(415) 558 3300

Los Angeles City Fire Department

California

4th to 7th June

Bureau of Fire Prevention & Public Safety

Los Angeles provided a number of opportunities to look at various types of housing caring for those with a disability. Again it appeared that they do not have any large-scale integration of people into the wider community with similar disabilities as those in CRU type housing in Victoria.

Persons with more profound disabilities as it was expressed to me are still housed in large type institutions similar to Kew Cottages in Melbourne.

After much searching various government departments for assistance in finding housing like CRU's we were put in touch with Lisa Burney who manages 8 homes similar to CRU's. Lisa was very interested in viewing the program that we had developed.

Eileen Landacre who is with the Los Angeles City Fire Department was very helpful in tracing CRU type homes as she works with the disabled for the Fire Department. She said that most of her contact with the disabled community consisted of people with sight, hearing, mobility problems, or a combination of these. She said that most people with a mental and physical disability like those we have dealt with were in the main still in institutional type settings. The few people with this type disability that she had dealt with had acquired the disability as the result of some trauma such as a car accident.

Eileen did take me to a large apartment complex that was exclusively for people that were deaf. The complex had some very unique safety features.

In short though again the specific type of CRU housing as exists in Melbourne seemed not to exist in Los Angeles.

Spoke to the following people:

5th June

Eileen Landacre City of Los Angeles Fire Department

Eileen was responsible for delivery of fire safety lectures to people with a disability. This group consisted in the main of people who had one of the following or a combination of these disabilities sight, hearing, and mobility impairment. When I spoke to her she at first said that she had many contacts that may be of assistance to me. But after many false starts in which the definition of what constituted a CRU home she said that they did not exist in a similar form as they do in Melbourne.

In the main housing for people with a disability was consisted of either home family care or the larger institutions like Kew Cottages. There were many homes for people with sight and hearing disabilities. One of these I visited was a large complex for the deaf. The 20 storey apartment had been set up to cater for the hearing impaired. They used internal television to put over emergency warnings and instructions; this was all integrated with internal flashing lights in people's apartments. It was interesting to note that the smoke alarms in the building were not designed for the hearing impaired, but relied upon the signal being transmitted to a central manager's office who then alerted the occupant.

All occupants were required to attend at least 3 evacuation drills a year as part of their tenancy.

All occupants that had a mobility impairment were placed on a register located in the alarm panel box so the arriving fire department were aware of their location

This complex had one of the best-organised and documented fire safety set ups I had come across in the US.

6th June

Lisa Burne Valley Villages

Lisa is a Qualified Mental Retardation Professional and manages 8 homes for people with a physical and mental disability; the homes are located throughout the City of Los Angeles.

The homes cater to people that had suffered some brain trauma injury or had very mild intellectual and physical disability. Most of the occupants in the homes in her charge were capable of doing many things on their own merits but did need supervision on a daily basis. So they were not like CRU housing in Melbourne in a strict sense.

Lisa expressed her surprise at the number of homes and people that had been placed back into the wider community. She said this had not happened in California on such a large scale. Many people had been placed back into the community that had or were suffering from some form of mental illness or disability and that this was an area of major concern re housing and care of these people.

There was no formal training in place for staff who worked in housing similar to Valley Village only loose guidelines and an annual inspection which was very brief. The main concern was placed on having a portable fire extinguisher and smoke alarms in place. Emergency procedures were to be kept in a folder that the Fire marshal needed to sight only. She said that renovations had recently been completed to the residence I was at but the additions had not been noted by the Fire Marshal during his inspection.

Lisa would like to see some form of uniform training for staff who worked in similar homes. She viewed our program and expressed her congratulations on it being a very comprehensive document and the ease with which staff could

complete the task whilst on duty, also the fact that a review of all topics could easily be done at staff meetings.

A copy of the program was left with Lisa and Eileen as they would both like to see if it could be modified to fit in with training for staff in homes like Village Valley.

Major Contacts City of Los Angeles:

Lisa Burne

Qualified Mental Retardation Professional
20830 Sherman Way
Canogo Park
CA 91306 2782
USA
(818) 587 9450

Eileen Landacre

Community Service Representative
Los Angeles City Fire Department
5021 N. Sepulveda Boulevard
Sherman Oaks
CA. 91403
(818) 756 9671

APPENDIX 1

Phoenix Arizona



If you have any questions or you would like one of our members to assist you, please call the Phoenix Fire Department - Division of Urban Services, Urban Survival for Business office at 262-7833 or 262-7840.



Published by Phoenix Fire Department, Corporate Communications, March 1997

Phoenix Fire Department

Urban Survival FOR BUSINESS

Safety Checklist



The Phoenix Fire Department responds to over 100,000 fire or medical emergencies each year. Many of these emergencies occur in business occupancies. The Urban Survival for Business Section of the Phoenix Fire Department is interested in providing you an opportunity to identify safety conditions within your workplace.

This checklist is for the sole use of the business owner/occupant to enhance your awareness of fire and life safety in his/her place of business and is not intended to regulate any portion of the City of Phoenix Fire Code.

- | | Yes | No |
|---|--------------------------|--------------------------|
| ● Is the address clearly visible and marked in large numbers to be seen from the street? | <input type="checkbox"/> | <input type="checkbox"/> |
| ● Is the fire extinguisher in a visible and accessible location? | <input type="checkbox"/> | <input type="checkbox"/> |
| ● Is the fire extinguisher classification 2A10BC or a greater classification? | <input type="checkbox"/> | <input type="checkbox"/> |
| ● Is there at least one fire extinguisher within 75' travel distance from anywhere in the business? | <input type="checkbox"/> | <input type="checkbox"/> |
| ● Has the fire extinguisher been serviced within the last year? | <input type="checkbox"/> | <input type="checkbox"/> |
| ● Is there only one thumb turn or key lock on each exit door? (no slide-bolts) | <input type="checkbox"/> | <input type="checkbox"/> |
| ● Does required exit door(s) have a sign which reads "this door to remain unlocked during business hours"? | <input type="checkbox"/> | <input type="checkbox"/> |
| ● Are exits identified and/or lit, if illuminated? | <input type="checkbox"/> | <input type="checkbox"/> |
| ● Is the rear exit door marked with an exit sign? | <input type="checkbox"/> | <input type="checkbox"/> |
| ● Do the electrical panels have a 30 inch clearance in front for easy access? | <input type="checkbox"/> | <input type="checkbox"/> |
| ● Are all stored materials stacked so they are at least 2 feet below the ceiling? | <input type="checkbox"/> | <input type="checkbox"/> |
| ● If you have emergency lighting, does it work? | <input type="checkbox"/> | <input type="checkbox"/> |
| ● Are areas outside and around the building free of dry weeds, debris or trash? | <input type="checkbox"/> | <input type="checkbox"/> |
| ● Are extension cords less than 6 feet long and used only for temporary wiring? ... | <input type="checkbox"/> | <input type="checkbox"/> |
| ● Does electrical outlet(s) have two (2) or less appliances plugged into it? | <input type="checkbox"/> | <input type="checkbox"/> |
| ● Do the telephones have 911 stickers on them? | <input type="checkbox"/> | <input type="checkbox"/> |
| ● Are all large commercial dumpsters (garbage containers) at least 5 feet away from combustable walls, window or door openings, or combustable roofs? | <input type="checkbox"/> | <input type="checkbox"/> |
| ● Is there less than 6 gallons of combustable or flammable liquids stored on site? | <input type="checkbox"/> | <input type="checkbox"/> |

If the answer to any of these questions is No, you should correct the situation so that the answer is Yes. A "yes" answer would indicate item is in compliance. It is the responsibility of the occupant to comply with the checklist by making all necessary corrections, if needed.

Our goal is to increase your awareness of Fire and Life Safety, reduce your risks and liability, and to make your business a safer place for everyone in the community.

- the space between the door and its frame. If you feel any warmth at all, use an alternate escape route. If the door feels cool, open it carefully and be ready to slam it shut if smoke or heat rushes in.
- Never use an elevator during a fire. It may stop at a floor where the fire is burning or malfunction and trap you. Go directly to a stairwell that's free of smoke and flames.

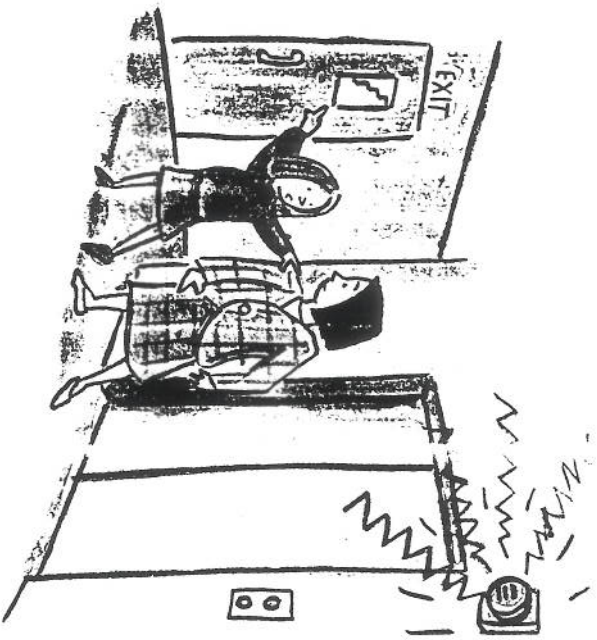

- Once you are out, stay out and keep out of the way of firefighters. Tell the fire department if you know of anyone trapped in the building. Do not go back inside, for any reason, until the firefighters tell you it is safe to do so.

If you stay:

- Stay calm. There are many things you can do to protect yourself.
- If possible, go to a room with an outside window and a telephone.
- Close the door between you and the fire. Stuff the cracks around the door with towels, rags, or bedding, and cover vents if smoke is coming out.
- If there's a phone in the room where you're trapped, call the fire department to report exactly where you are. Do this even if you can see fire trucks on the street below.
- Wait at a window and signal for help with a flashlight, if you have one, or by waving a sheet or other light-colored cloth.
- If possible, open the window at the top and bottom, but do not break the window. Be ready to close the window quickly if smoke rushes in.
- Be patient. Rescuing all the occupants of a high-rise building can take several hours.

Fire Safety in High-Rise Buildings

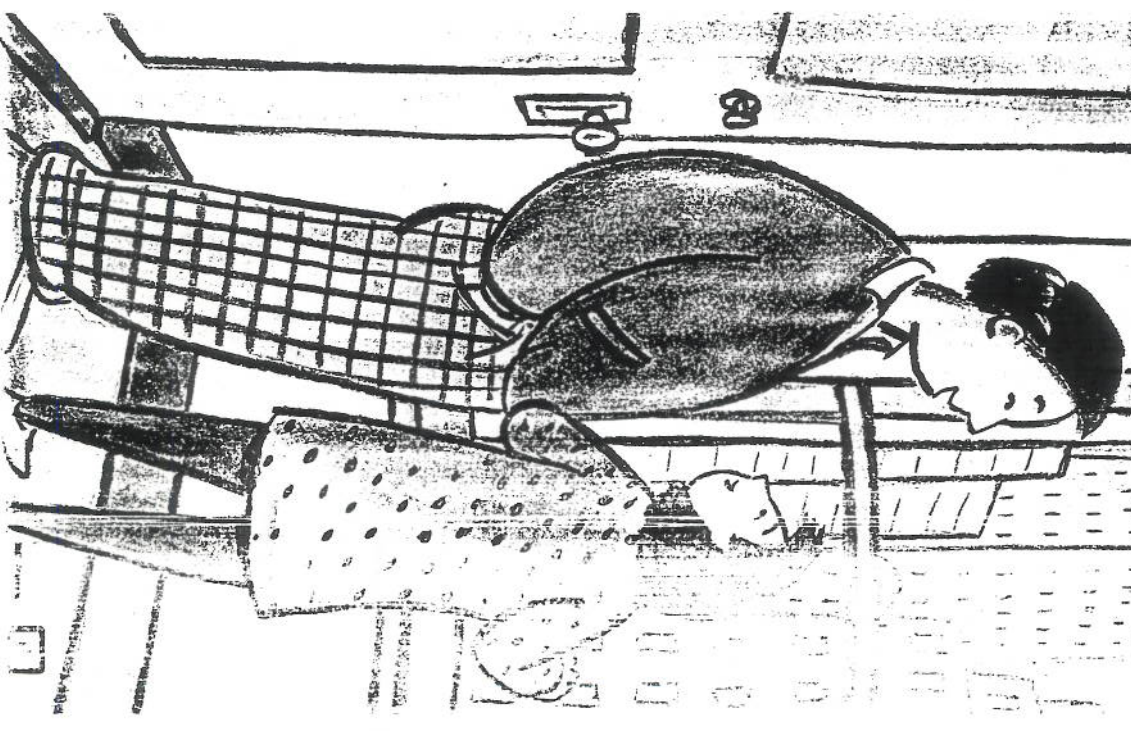

People Protecting People Since 1896
 ©1997 National Fire Protection Association
 Batterymarch Park, Quincy, MA 02269-9101
 NFPA

Printed in the U.S.A. BR-29F
 recycled paper



Fire-Safe Living in High-Rise Buildings

High-rise apartments and condos present special fire-safety concerns. When strictly enforced, fire and construction codes can ensure that high-rises are designed to minimize the likelihood of a major fire. But high-rise fires do happen.

High-rise home fires result from the same causes as fires in other homes—cooking an overheating piece of equipment, electrical systems, arson smoking, and children playing with matches and lighters.

Building Safety

To save lives and minimize property damage, the fire-safety features of your apartment or condominium building must be inspected and maintained.

Alarms, Emergency Lighting, and Sprinkler Systems

Find out who is responsible for maintaining these important safety systems in your building. Make sure that nothing blocks or otherwise interferes with such devices, and promptly report any sign of damage or malfunction to building management.

Fire Exits

Never lock fire exits or block doorways, halls, or stairways. Fire doors not only provide a way out during a fire, but they also slow the spread of flames and smoke. Never prop open fire doors.

Be Prepared

You are far more likely to do the right thing in a real fire if you are prepared for the emergency.

- Learn your building's evacuation plans. Make sure everyone in your household knows where to go if the fire alarm sounds, and practice your escape plan together. Your building manager should post evacuation plans in high-traffic common areas, such as lobbies.
- Learn the sound of your building's fire alarm.
- Know at least two escape routes from every room in your apartment or condo, and learn every exit from your building.



- In the event of a fire, you may have to escape in the dark by feeling your way along the wall. Be prepared. Count the number of doors between your living unit and the two nearest building exits.
- Know where to find your building's fire alarms, and learn how to use them.
- Post emergency fire department numbers near all telephones.

KNOW WHEN TO GO

Survival procedures for high-rise buildings are similar to those for other buildings, but with large numbers of people leaving at the same time—some of them from upper floors—cooperation and precision are all the more important.

Some building-evacuation plans may require you to go to a “safe area” inside the building and wait for the fire department to supervise evacuation.

Consult your building management or fire department, and know what to do in advance.

- If you discover a fire, sound the alarm and call the fire department.
- If you can hear instructions over your building's public-address system, listen carefully and do as you are told. You might be told to stay where you are.
- Follow your building's evacuation plan exactly, unless doing so puts you in immediate danger.

If you leave:

- Leave the fire area quickly, closing all doors behind you to slow the spread of fire and smoke.
- If you encounter smoke or flames, use an alternative escape route. If you must escape through smoke, crawl low. Heat and smoke rise. Cleaner air will be 12 to 24 inches (30 to 60 centimeters) above the floor.
- Test doors before you open them. Kneeling or crouching, reach up as high as you can and with the back of your hand touch the door, the knob, and



HOW TO FIRE SAFETY & SECURITY

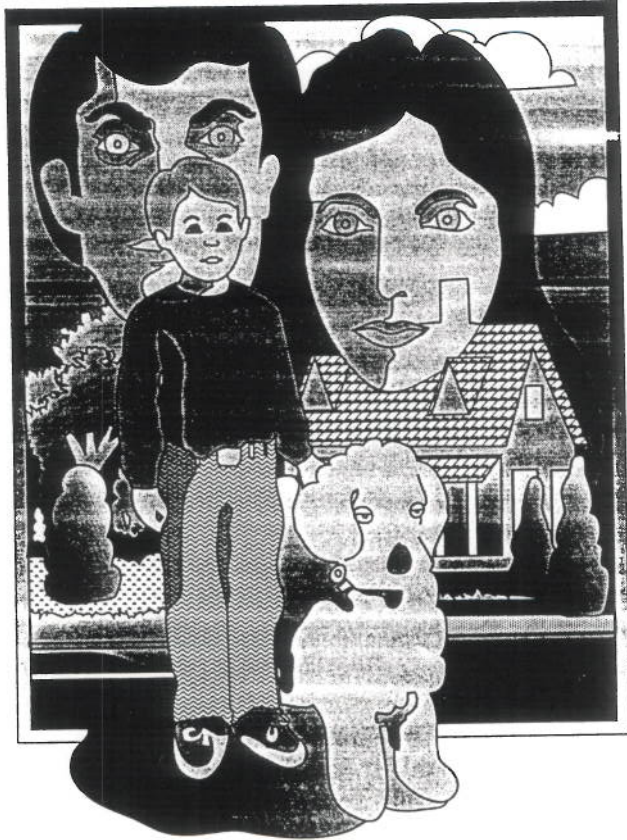

A Property Conservation Resource from
Factory Mutual Engineering and Research

Fire in Your Home

PREVENTION AND SURVIVAL



National Fire Protection
Association

DDD LIFE SAFETY INSPECTION: GUIDELINES FOR COMPLIANCE WORKSHEET

Biennial Life Safety/Fire Inspection Requirements

-
- ▶ Requirements for HCBS service providers: R6-6-1505.B - Except as provided by R6-6-1521, the applicant shall have a fire department or individual approved by the Division perform a fire inspection at the time of the initial application and every two years after, on each residence or facility which the applicant owns, rents, or leases, and in which services are to be provided, unless the services are provided in the client's home. The applicant shall maintain the results of the fire inspection of file.
 - ▶ Requirements for ADH/CFH licensed settings; shall pass fire inspection has required by HCBS certification; additionally;
 - ▶ R6-6-1111.E and R6-6-1011 - Adult/Child developmental homes located in **mobile homes** shall pass an **annual** fire safety inspection as arranged by the Division.
-

- Each facility certified by Home and Community Based Services (HCBS), that provides services in a facility, other than the clients own home, shall have a Life Safety/Fire inspection completed every two years by state or local fire authorities, approved by the Division.
- This requirement includes: Day Care and Day Programs for adults or children, Residential Respite, Residential CFH or ADH Licensed settings, Health Care occupancies providing speech, hearing or physical therapy, or Workshops. The service provider shall maintain a written report from the Life Safety/fire authority on file at the setting.
- The worksheet has been provided to give the provider an opportunity to review prior to Initial or Renewal inspection, the minimum standards the setting will be inspected to, to maintain certification.
- The worksheet was formatted to be used has a guide to inform and be completed by the service provider for a self in-home inspection, to prepare your setting for the pending scheduled inspection.
- By providing guidelines for compliance the desired result is that the service provider has an opportunity to be informed and equipped to complete the life safety requirements for certification, and provide a safer more productive environment for the clients we serve.
- The service provider can expect to be called by a Life Safety representative to set an inspection date for renewal, relocation or a first time provider initial inspections.

Guidelines for Compliance:

1. The address of the setting is posted and clearly visible from the street. If posting is not possible, local emergency services have been notified of the location of the home.

- ▶ *Posted directly on the facility and legible from the street.*
 - ▶ *Numbers should be contrasting colors to base.*
 - ▶ *If setting is at a distance from curb, place numbers on mail box*
-

2. Automatic smoke detectors are working and are placed in each sleeping room of the residential setting:

A. HCBS requires one smoke detector in respite sleeping room only and one smoke detector in central location of residence; and

B. HCBS requires for day care/programs, health care, one smoke detector in a centralized location.

C. CFH/ADH licensed residential settings require a smoke detector placed in each sleeping room and in a smoke detector placed in a centralized location of the residence.

- ▶ *Placement: One smoke detector per sleeping room, away from obstruction, meaning; do not place detector in a dead air pocket, or too close to air handling unit discharge outlets. Best location; detector mounted on the ceiling in the center of the room; other approved location; mounted on the wall, no higher than four inches measured down from ceiling and no lower than twelve inches measured down from the ceiling.*
 - ▶ *Maintenance: Check smoke detectors monthly to make sure it is not damaged or inoperative, test battery, replace battery(s) annually. If facility utilizes hard wired detectors, units should have battery back up.*
 - ▶ *If facility utilizes hard wired smoke detectors, the system should have battery back up. maintenance should be followed as above.*
 - ▶ **SMOKE DETECTORS SAVE LIVES WHEN WORKING.** *For residential settings smoke detectors are vital in early warning, automatically detecting a fire by sensing smoke particles and indicating to residents inside an emergency. Develop an effective monthly system to ensure operation at all times.*
-

3. A minimum of one 2A:10B:C fire extinguisher is available in the setting. All fire extinguishers are serviced annually or as recommended by the manufacturer. All fire extinguishers are tagged specifying the date of purchase or the date of servicing, whichever is more recent, and the company performing the servicing work, if applicable.

- ▶ *The maximum travel distance to access a fire extinguisher is 75 feet, without having to pass through a locked passageway.*
- ▶ *Dry chemical extinguisher/stored pressure type, typically 5lb hand portable, Ammonium Phosphate Base agent, with a classification of 2A:10B:C.*
- ▶ *Suitability rating; Class A: fires of ordinary combustible materials (wood, cloth, paper, rubber), Class B: fires of flammable or combustible liquids (flammable gases, greases), Class C: fires in live electrical equipment.*
- ▶ *Numerical rating provides information on effectiveness of extinguisher on that class of fire. Example: a extinguisher with a 10B rating can be expected to extinguish a fire of 10 square feet of an 8 inch deep layer of flammable liquid. This rating is for an untrained operator. A trained operator should be able to extinguish 25 square feet.*
- ▶ *Hand portable extinguishers will have discharge times of 8 to 25 seconds. The discharge range will vary from 5 to 20 feet.*
- ▶ *User should know how to operate an extinguisher, read instructions, ask about training at local fire station, remember; PULL-POINT-PRESS-SWEEP.*
- ▶ *Placement: Top of extinguisher not more than five feet above floor. Near but not in kitchen (scene of most fires).*
- ▶ *Maintenance: Annual service or purchase new extinguisher (keep receipt). Monthly checks; confirm that the extinguisher is in its proper place, access not obstructed. Operating instructions face forward. Confirm that seals/plastic tamper indicator are intact. Confirm that the pressure gauge is in the normal range. Check hose/nozzle is clear of powder, (small discharge could develop).*

4. All stairways, hallways, walkways and other routes of evacuation are free from obstacles that prohibit exit in case of emergency.

- ▶ *Locks, bars, grilles, grates, or similar devices installed on windows or doors which are used for emergency exit are equipped with release mechanisms which are operable from the inside without the use of a key or special knowledge or effort.*
 - ▶ *The use of keyed locks (deadbolts, security devices) from the inside is prohibited in residential settings, at evacuation routes.*
 - ▶ *Commercially zoned occupancies that operate day care or limited health care, may have keyed locks at evacuation routes, but, must post a sign at exit which states; door to be kept unlocked during business hours.*
 - ▶ *All doorways and doorways to exit discharges on the interior side, must be kept accessible and in operable condition.*
-

5. Each sleeping room has at least one operable window or door that opens onto a street, alley, yard or exit court for emergency exit.

- ▶ *Two exits from each room; Primary exit (entry door, door person used to enter room), Secondary exit (window or door, to outside from same room).*
 - ▶ *Obstruction free, no keyed locks, security devices.*
-

6. A evacuation plan (floor plan) of the setting is available which designates the routes of evacuation, location of fire fighting equipment and location of evacuation devices. (Note: The floor plan is not required to be posted unless the setting serves seven or more residents. In this case, the floor plan must be posted on each floor and wing, if applicable.)

- ▶ *Evacuation plan can be placed with other emergency plan information or provider documents, in file. If seven or more the plan must be posted in a conspicuous place.*
- ▶ *Emergency plans for each client, a brief statement, giving direction of the clients emergency needs, should be provided.*
- ▶ *Emergency plan instructions could be as simple as: REACT:*

Remove threatened people

Ensure door is closed

Alarm is sounded

Call fire department

Try to extinguish - if safe

or using the EDITH (Exit Drill In The Home) system.

- ▶ *A fire drill should be held at least once or twice annually. There should be a designated meeting place and it should include different scenarios of where the fire might be located, (primary location is the kitchen). The drill should be evaluated and documented with all occupants participating to be familiar with fire drill as soon as in home, developing a fire risk profile of the clients in the home. This practice helps identify the clients emergency needs.*
 - ▶ *For ADH/CFH a fire drill must be conducted after a move to a new setting; a change in evacuation/emergency plan; or when a new client moves into the setting.*
-

7. The setting has a working telephone (ADH/CFH requirement), or, for respite only, a two-way communications system to contact emergency personnel. Emergency telephone numbers for fire, police and local emergency medical personnel, or 911, as appropriate for the local community, are available and in close proximity to telephones in the setting.

- ▶ *The provider must have an effective means of communication to ensure emergency personnel will respond.*
-

8. The setting is free from obvious, blatant electrical hazards.

- ▶ *The premises is free from defective electrical wiring, appliances and equipment.*
 - ▶ *Electrical outlet covers are not missing, in good condition and cover the receptacle box. Safety covers when appropriate are in place on unused outlets. Electrical outlets are not overloaded.*
 - ▶ *Only approved electrical extension power cords are used, are in good condition and are not placed under carpets, throw rugs, through walls or door ways. Electrical extension cords are not used in place of permanent wiring (temporary use is considered any time frames, that does not extend overnight).*
 - ▶ *Covers of fuse, breakers and switch boxes are kept closed. Fuses are of the proper capacity for the circuits served. The main entrance switches and panel boards are unobstructed, labeled, and readily accessible. GFCI breakers used in appropriate locations.*
-

9. Combustibles or flammable materials are not stored within three feet of furnaces, heaters, or water heaters.

- ▶ *Space heaters are responsible for more than 30 percent of fatal fires, the unit must be UL listed (United Laboratories) and supplied with a knock over shut off safety switch. Space heaters should not be utilized as the primary source of heating in a room or home.*
 - ▶ *Kerosene not permitted in residence.*
 - ▶ *Storage of flammable liquids; gasoline: stored in approved containers, in a separate, well-ventilated storage room. Storage room is clean and free of rubbish. No more than five gallons in the garage connected to the home.*
 - ▶ *Hot water heaters should be installed to code, with T&P valve connected with drain pipe away from controls.*
 - ▶ *Attic crawl hole cover in place, all ceiling areas and walls are intact, no holes for fire to spread quickly.*
 - ▶ *Pool chemicals are in original containers and are not stored in the setting. In the separate storage area, the chemicals are secured away from other chemicals in dry location. Calcium Hypochlorite is an oxidizer: supplies its own oxygen that keep fires going. Keep separate from Acids..*
-

10. As applicable, each operable fireplace in the setting is protected at all times by a fire screen or metal curtain.

- ▶ *Fire places have screens on front to protect from sparks.*
-

11. The premises does not have an accumulation of litter, rubbish or garbage that may be considered a fire hazard.

- ▶ *Combustible refuse is hauled away at regular intervals and not permitted to accumulate on the premises.*
 - ▶ *Good housekeeping practices are observed inside and outside the setting; safely organized, uncultured, clean and orderly. Materials stored properly, neatly, away from other incompatible materials.*
-

DDD LIFE SAFETY INSPECTION: GUIDELINES FOR COMPLIANCE WORKSHEET

Biennial Life Safety/Fire Inspection Requirements

-
- ▶ Requirements for HCBS service providers: R6-6-1505.B - Except as provided by R6-6-1521, the applicant shall have a fire department or individual approved by the Division perform a fire inspection at the time of the initial application and every two years after, on each residence or facility which the applicant owns, rents, or leases, and in which services are to be provided, unless the services are provided in the client's home. The applicant shall maintain the results of the fire inspection of file.
 - ▶ Requirements for ADH/CFH licensed settings; shall pass fire inspection has required by HCBS certification; additionally;
 - ▶ R6-6-1111.E and R6-6-1011 - Adult/Child developmental homes located in **mobile homes** shall pass an **annual** fire safety inspection as arranged by the Division.
-

- Each facility certified by Home and Community Based Services (HCBS), that provides services in a facility, other than the clients own home, shall have a Life Safety/Fire inspection completed every two years by state or local fire authorities, approved by the Division.
- This requirement includes: Day Care and Day Programs for adults or children, Residential Respite, Residential CFH or ADH Licensed settings, Health Care occupancies providing speech, hearing or physical therapy, or Workshops. The service provider shall maintain a written report from the Life Safety/fire authority on file at the setting.
- The worksheet has been provided to give the provider an opportunity to review prior to Initial or Renewal inspection, the minimum standards the setting will be inspected to, to maintain certification.
- The worksheet was formatted to be used has a guide to inform and be completed by the service provider for a self in-home inspection, to prepare your setting for the pending scheduled inspection.
- By providing guidelines for compliance the desired result is that the service provider has an opportunity to be informed and equipped to complete the life safety requirements for certification, and provide a safer more productive environment for the clients we serve.
- The service provider can expect to be called by a Life Safety representative to set an inspection date for renewal, relocation or a first time provider initial inspections.

Guidelines for Compliance:

1. The address of the setting is posted and clearly visible from the street. If posting is not possible, local emergency services have been notified of the location of the home.

- ▶ *Posted directly on the facility and legible from the street.*
 - ▶ *Numbers should be contrasting colors to base.*
 - ▶ *If setting is at a distance from curb, place numbers on mail box*
-

2. Automatic smoke detectors are working and are placed in each sleeping room of the residential setting:

A. HCBS requires one smoke detector in respite sleeping room only and one smoke detector in central location of residence; and

B. HCBS requires for day care/programs, health care, one smoke detector in a centralized location.

C. CFH/ADH licensed residential settings require a smoke detector placed in each sleeping room and in a smoke detector placed in a centralized location of the residence.

- ▶ *Placement: One smoke detector per sleeping room, away from obstruction, meaning; do not place detector in a dead air pocket, or too close to air handling unit discharge outlets. Best location; detector mounted on the ceiling in the center of the room; other approved location; mounted on the wall, no higher than four inches measured down from ceiling and no lower than twelve inches measured down from the ceiling.*
 - ▶ *Maintenance: Check smoke detectors monthly to make sure it is not damaged or inoperative, test battery, replace battery(s) annually. If facility utilizes hard wired detectors, units should have battery back up.*
 - ▶ *If facility utilizes hard wired smoke detectors, the system should have battery back up. maintenance should be followed as above.*
 - ▶ **SMOKE DETECTORS SAVE LIVES WHEN WORKING.** *For residential settings smoke detectors are vital in early warning, automatically detecting a fire by sensing smoke particles and indicating to residents inside an emergency. Develop an effective monthly system to ensure operation at all times.*
-

3. A minimum of one 2A:10B:C fire extinguisher is available in the setting. All fire extinguishers are serviced annually or as recommended by the manufacturer. All fire extinguishers are tagged specifying the date of purchase or the date of servicing, whichever is more recent, and the company performing the servicing work, if applicable.

- ▶ *The maximum travel distance to access a fire extinguisher is 75 feet, without having to pass through a locked passageway.*
- ▶ *Dry chemical extinguisher/stored pressure type, typically 5lb hand portable, Ammonium Phosphate Base agent, with a classification of 2A:10B:C.*
- ▶ *Suitability rating; Class A: fires of ordinary combustible materials (wood, cloth, paper, rubber), Class B: fires of flammable or combustible liquids (flammable gases, greases), Class C: fires in live electrical equipment.*
- ▶ *Numerical rating provides information on effectiveness of extinguisher on that class of fire. Example; a extinguisher with a 10B rating can be expected to extinguish a fire of 10 square feet of an 8 inch deep layer of flammable liquid. This rating is for an untrained operator. A trained operator should be able to extinguish 25 square feet.*
- ▶ *Hand portable extinguishers will have discharge times of 8 to 25 seconds. The discharge range will vary from 5 to 20 feet. .*
- ▶ *User should know how to operate an extinguisher, read instructions, ask about training at local fire station, remember; PULL-POINT-PRESS-SWEEP.*
- ▶ *Placement: Top of extinguisher not more than five feet above floor. Near but not in kitchen (scene of most fires).*
- ▶ *Maintenance: Annual service or purchase new extinguisher (keep receipt). Monthly checks; confirm that the extinguisher is in its proper place, access not obstructed. Operating instructions face forward. Confirm that seals/plastic tamper indicator are intact. Confirm that the pressure gauge is in the normal range. Check hose/nozzle is clear of powder, (small discharge could develop).*

4. All stairways, hallways, walkways and other routes of evacuation are free from obstacles that prohibit exit in case of emergency.

- ▶ *Locks, bars, grilles, grates, or similar devices installed on windows or doors which are used for emergency exit are equipped with release mechanisms which are operable from the inside without the use of a key or special knowledge or effort.*
 - ▶ *The use of keyed locks (deadbolts, security devices) from the inside is prohibited in residential settings, at evacuation routes.*
 - ▶ *Commercially zoned occupancies that operate day care or limited health care, may have keyed locks at evacuation routes, but, must post a sign at exit which states; door to be kept unlocked during business hours.*
 - ▶ *All doorways and doorways to exit discharges on the interior side, must be kept accessible and in operable condition.*
-

5. Each sleeping room has at least one operable window or door that opens onto a street, alley, yard or exit court for emergency exit.

- ▶ *Two exits from each room; Primary exit (entry door, door person used to enter room), Secondary exit (window or door, to outside from same room).*
 - ▶ *Obstruction free, no keyed locks, security devices.*
-

6. A evacuation plan (floor plan) of the setting is available which designates the routes of evacuation, location of fire fighting equipment and location of evacuation devices. (Note: The floor plan is not required to be posted unless the setting serves seven or more residents. In this case, the floor plan must be posted on each floor and wing, if applicable.)

- ▶ *Evacuation plan can be placed with other emergency plan information or provider documents, in file. If seven or more the plan must be posted in a conspicuous place.*
- ▶ *Emergency plans for each client, a brief statement, giving direction of the clients emergency needs, should be provided.*
- ▶ *Emergency plan instructions could be as simple has; REACT:*

Remove threatened people
Ensure door is closed
Alarm is sounded
Call fire department
Try to extinguish - if safe

or using the EDITH (Exit Drill In The Home) system.

- ▶ *A fire drill should be held at least once or twice annually. There should be a designated meeting place and it should include different scenarios of where the fire might be located, (primary location is the kitchen). The drill should be evaluated and documented with all occupants participating to be familiar with fire drill as soon as in home, developing a fire risk profile of the clients in the home. This practice helps identify the clients emergency needs.*
 - ▶ *For ADH/CFH a fire drill must be conducted after a move to a new setting; a change in evacuation/emergency plan; or when a new client moves into the setting.*
-

7. The setting has a working telephone (ADH/CFH requirement), or, for respite only, a two-way communications system to contact emergency personnel. Emergency telephone numbers for fire, police and local emergency medical personnel, or 911, as appropriate for the local community, are available and in close proximity to telephones in the setting.

- ▶ *The provider must have an effective means of communication to ensure emergency personnel will respond.*
-

8. The setting is free from obvious, blatant electrical hazards.

- ▶ *The premises is free from defective electrical wiring, appliances and equipment.*
 - ▶ *Electrical outlet covers are not missing, in good condition and cover the receptacle box. Safety covers when appropriate are in place on unused outlets. Electrical outlets are not overloaded.*
 - ▶ *Only approved electrical extension power cords are used, are in good condition and are not placed under carpets, throw rugs, through walls or door ways. Electrical extension cords are not used in place of permanent wiring (temporary use is considered any time frames, that does not extend overnight).*
 - ▶ *Covers of fuse, breakers and switch boxes are kept closed. Fuses are of the proper capacity for the circuits served. The main entrance switches and panel boards are unobstructed, labeled, and readily accessible. GFCI breakers used in appropriate locations.*
-

9. Combustibles or flammable materials are not stored within three feet of furnaces, heaters, or water heaters.

- ▶ *Space heaters are responsible for more than 30 percent of fatal fires, the unit must be UL listed (United Laboratories) and supplied with a knock over shut off safety switch. Space heaters should not be utilized as the primary source of heating in a room or home.*
 - ▶ *Kerosene not permitted in residence.*
 - ▶ *Storage of flammable liquids; gasoline: stored in approved containers, in a separate, well-ventilated storage room. Storage room is clean and free of rubbish. No more than five gallons in the garage connected to the home.*
 - ▶ *Hot water heaters should be installed to code, with T&P valve connected with drain pipe away from controls.*
 - ▶ *Attic crawl hole cover in place, all ceiling areas and walls are intact, no holes for fire to spread quickly.*
 - ▶ *Pool chemicals are in original containers and are not stored in the setting. In the separate storage area, the chemicals are secured away from other chemicals in dry location. Calcium Hypochlorite is an oxidizer: supplies its own oxygen that keep fires going. Keep separate from Acids..*
-

10. As applicable, each operable fireplace in the setting is protected at all times by a fire screen or metal curtain.

- ▶ *Fire places have screens on front to protect from sparks.*
-

11. The premises does not have an accumulation of litter, rubbish or garbage that may be considered a fire hazard.

- ▶ *Combustible refuse is hauled away at regular intervals and not permitted to accumulate on the premises.*
 - ▶ *Good housekeeping practices are observed inside and outside the setting; safely organized, uncultured, clean and orderly. Materials stored properly, neatly, away from other incompatible materials.*
-

SMOKE DETECTORS



...BUT ONLY IF THEY'RE WORKING PROPERLY!



**MAKE TUESDAY
DETECTOR TEST DAY**

Remember,
Tuesday is test day so . . . MAKE IT PASS THE TEST

INSTALL the smoke detector correctly.

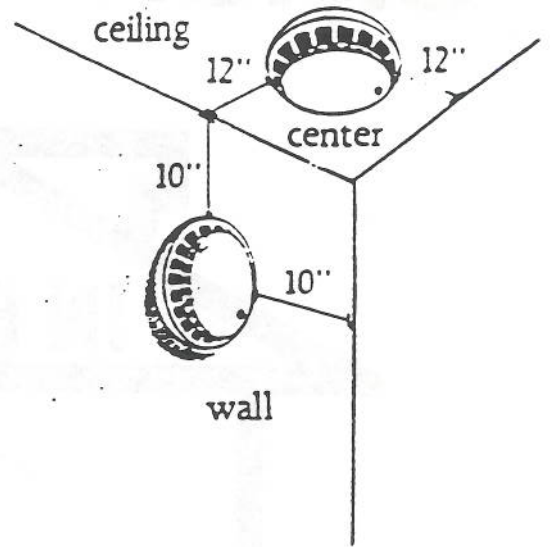

CLEAN it off

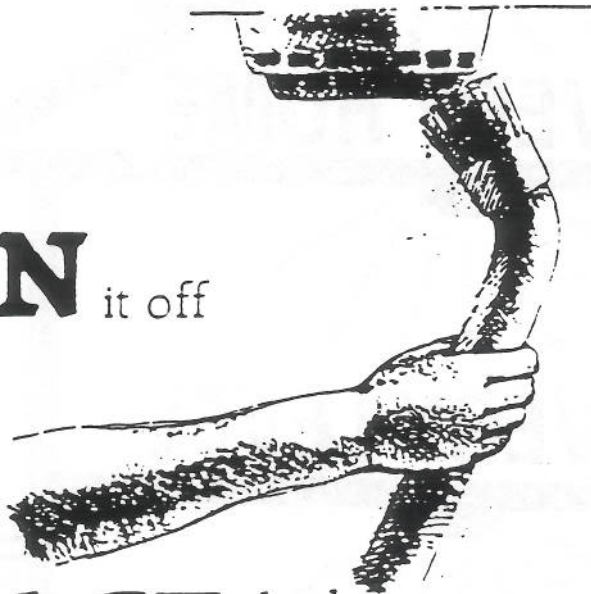

REPLACE the battery once a year

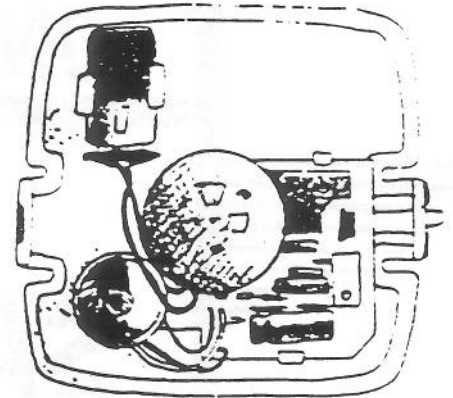

TEST it with smoke once a month



If your smoke detector sounds while you are cooking, or in other non-emergency situations, don't remove the battery or turn it off! Instead, contact your local fire department. We can help.

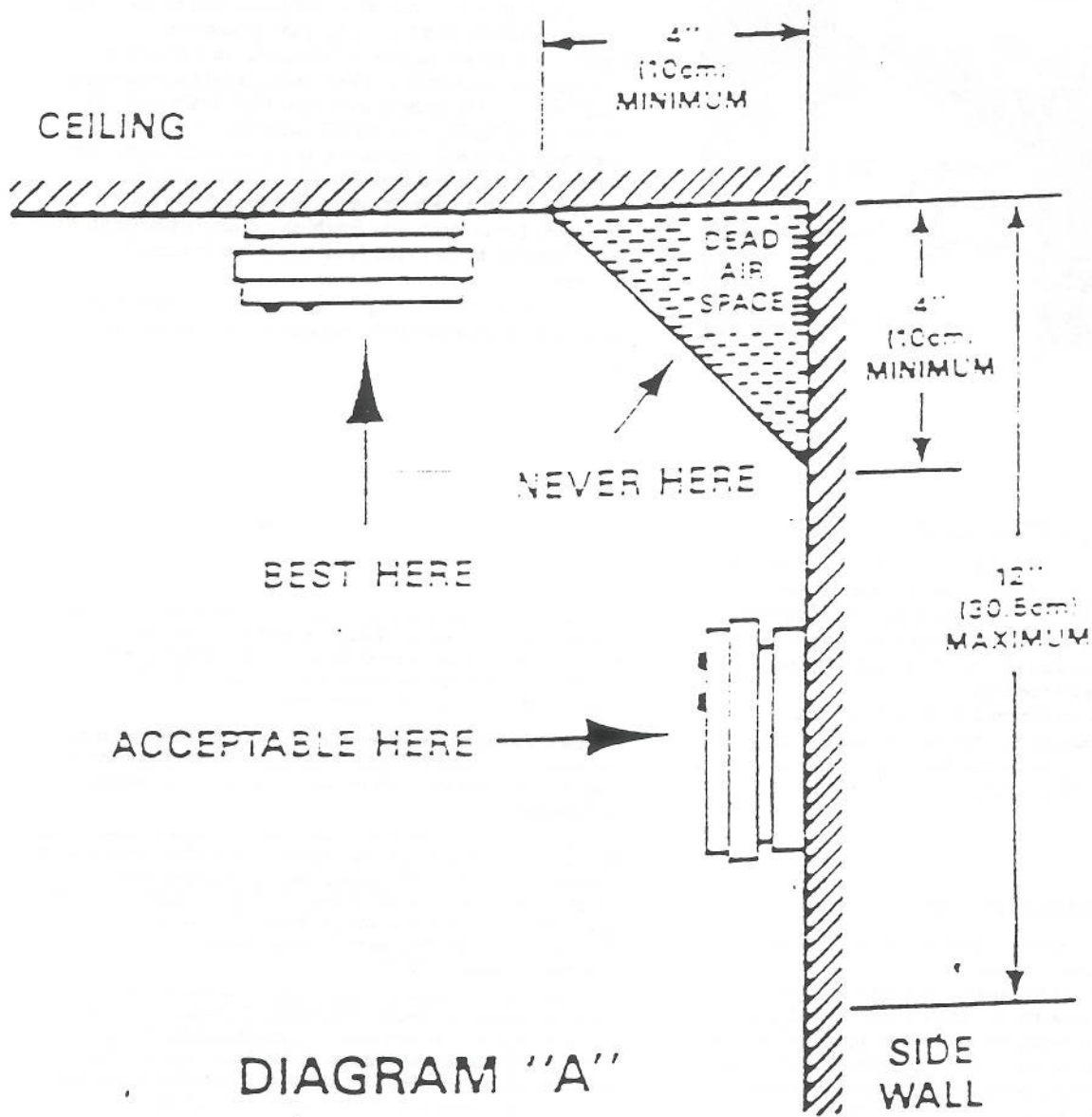
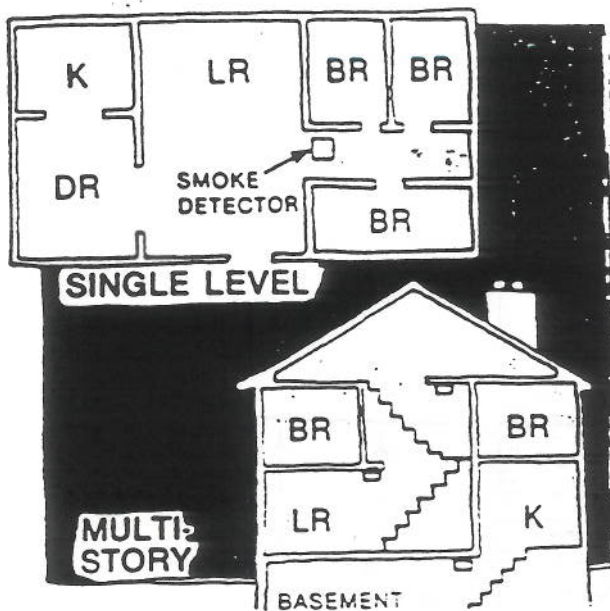

DIAGRAM "A"



Home fire safety

- **Minimize fire hazards.** Keep stoves and furnace rooms clean. Remove trash and garbage daily. Keep heating and electrical equipment properly maintained. Use properly sized wiring and fuses. Never smoke in bed. Do not leave children at home alone. Exercise caution when using flammable liquids. Never store or use gasoline inside the house.

- **Develop and practice an escape plan.** There is little time between detection of a fire and the time it becomes deadly—this interval may be as little as one or two minutes. Planning and practicing for fire conditions with emphasis on rapid exit from the home is important. Hold drills every six months so all family members will know exactly what to do. Everyone should have two escape routes—one through doors, hallways, or stairs; the other through windows. Teach everyone not to open bedroom doors if the door is hot, indicating fire on other side. Establish a meeting place outside, away from the house so family members can be quickly located.

- **Provide a fire warning system.** Smoke detectors warn occupants of a fire and give them a chance to escape—and live.

Location and installation

The purpose of smoke detectors is to wake you from a deep sleep if a fire should start. Always install at least one detector per floor near the bedroom area. Install the detectors in a centrally located hall of small, one-story homes. Use more units for a large, sprawling home, especially if the bedrooms are in separate parts of the house.

Install detectors on the ceiling for early, accurate fire detection. As an alternative to the ceiling location, install the detector on the wall as recommended by the manufacturer. In multi-story homes, install a unit near the top of the stairs.

Testing and maintenance

The Oregon Fire Service urges owners to check the operation of their detectors once a week.

Test each unit after installation as suggested by the manufacturer. Familiarize all family members with the alarm sound. Once a week check the battery and light bulb; if either is defective, replace. Always keep a spare replacement battery and light bulb. Vacuum detectors yearly to remove dust, insects, and spiders that can cause false alarms.

Once a month test your detector with real smoke. Use a smoldering cotton cord in an ashtray, a match, or other safe procedure to blow smoke into it. By using smoke you can be sure your detector will sound the alarm when it detects smoke during a real emergency. Pushing the test button is not enough!

The Oregon State University Extension Service provides education and information based on timely research to help Oregonians solve problems and develop skills related to youth, family, community, farm, forest, energy, and marine resources.

Extension's home economics program provides educational opportunities to help individuals and families manage their resources to meet needs for food, clothing, finance, shelter, parenting, and human relationships.

This publication was prepared by Suzanne B. Badenhop, Oregon State University Extension family housing and energy management specialist, in cooperation with the State of Oregon Fire Standards and Accreditation Board (FSAB) and the Oregon Fire Education Association (OFEA). This material is revised from Fire Alarm Systems for Homes, WRAES 51.

Extension Service, Oregon State University, Corvallis, O. E. Smith, acting director. This publication was produced and distributed in furtherance of the Acts of Congress of May 8 and June 30, 1914. Extension work is a cooperative program of Oregon State University, the U. S. Department of Agriculture, and Oregon counties.

Oregon State University Extension Service offers educational programs, activities, and materials without regard to race, color, national origin, or sex as required by Title VI of the Civil Rights Act of 1964 and Title IX of the Education Amendments of 1972. Oregon State University Extension Service is an Equal Opportunity Employer.

Smoke Detectors Fire Alarms for Your Home

- Smoke detectors provide inexpensive protection for you and your family.
- If a fire starts, smoke detectors give early warning of the danger so you can get out of the house safely.
- You should install smoke detectors on every level of your home to quickly alert occupants, day or night.
- To keep your detectors working, test them every week. Use real smoke. Be sure to replace worn-out batteries and bulbs immediately.

How fires kill

Fires develop in three stages:

- **First stage.** Invisible particles of combustion are produced without significant amounts of heat, flame, or smoke.
- **Second stage.** Primarily smoke is produced. Little heat or flame is present; and fire can be relatively easily extinguished, if detected.
- **Third stage.** Flames become clearly visible, heat increases, fire grows rapidly, and extinguishing becomes difficult.

The Oregon Fire Service reports that most people die in home fires from noxious gases, smoke, and lack of oxygen—often before they wake up. Many synthetic materials used in carpeting and home furnishings give off deadly gases when they smolder. For these reasons, the Oregon Fire Service recommends that you install at least one smoke detector on every level of your home.

Provide early warning

Smoke detectors sense fumes and smoke in early stages and warn you with an 82 to 90 decibel audible alarm signal (about as intense as an automobile horn or loud alarm clock). There are two basic types—ionization and photoelectric.

Ionization detectors offer the earliest warning because they sense gases in the air before smoke builds up. They use a radioactive source to produce a small amount of electric current in the detector chamber. When fumes or smoke enter the chamber, the flow of electric current changes and triggers the alarm.

Photoelectric detectors use a light source and electric eye. When smoke enters the chamber, the electronic eye senses a reduced amount of light and triggers the alarm.

In general, the photoelectric detector responds faster to small amounts of visible smoke from a smoldering fire. The ionization detector responds faster to flaming fires and to invisible gaseous products of combustion such as carbon monoxide.

Both type of detectors are effective for home fires. Their sensitivity makes them undesirable for use in kitchens, garages, or furnace rooms, but makes them desirable for use near bedrooms where the earliest possible warning of fire is necessary.

Battery or plug-in type

Each has its own advantages and disadvantages. Battery-type alarms are easy to install in areas without electric outlets. Independent of home current, they work in case of power outage.

Some authorities suggest the installation of both types of smoke detectors—one plug-in photoelectric and one battery-operated ionization unit. The differing sensitivities of the two types supplement each other, providing backup protection and an additional alarm.

Periodically check batteries; they usually need replacing once a year. Some detectors give off a warning signal when batteries get weak. It is a good idea to keep new batteries on hand.

House-powered models are the least difficult to maintain. They must have an unswitched outlet, preferably on a separate circuit. Photoelectric detectors always run on house current since they require more power than the ionization type. A photoelectric lamp bulb needs periodic checking and must be replaced every 2 to 3 years.

Buying tips

- Buy detectors approved by Underwriters' Laboratories (UL), Factory Mutual System (FM), or International Conference of Building Officials (ICBO).
- Buy only those models that have replacement batteries or bulbs readily available.
- Purchase detectors from a reputable firm.
- Obtain—and study—instruction booklet on installation, testing, and maintenance.



OREGON STATE UNIVERSITY EXTENSION SERVICE

FAMILY INSTRUCTIONS --



Gather your family together... for a short explanation of the vital nighttime fire escape procedures.

POINT 1 Always sleep with bedroom or hall door closed. It can keep out fire long enough to allow escape through your emergency escape route (usually a window). When you cannot have your bedroom door closed, then you must have a smoke detector.

POINT 2 Agree on a way everyone can sound a family fire alarm. Keep in mind that fire may block hallway, preventing you from reaching other bedrooms. You can pound on walls, holler, use a whistle, strike a pan, etc. Of course, the best alarm is a smoke detector. It never sleeps!

POINT 3 Don't waste time getting dressed or gathering valuables. Precious seconds can count in a fire!

POINT 4 Test doors before opening. Intense heat and deadly smoke may be on the other side... ready to strike you down in just a couple of breaths.

- | | |
|---|---|
| ● HOW TO "TEST" A DOOR:
Are door panels hot? Is smoke leaking in around edges? If you suspect fire on other side, DON'T OPEN THE DOOR. But if you think it's safe — open it cautiously. | ● HOW TO "OPEN" A DOOR:
Brace shoulder against door. Keep head to one side. Open door slightly. Ready to slam it if any heat and smoke rush in. |
|---|---|

POINT 5 Have an outside meeting place... to quickly check if everyone is safe. Once out — **STAY OUT!**

POINT 6 Notify Fire Department quickly, soon as everyone is out. Your phone may be out of reach or out of order. Plan to use a neighbor's phone (or street alarm box). Make sure your phone and your neighbor's phone have the house address nearby. If you have a guest or babysitter in your home, show them where the address is written. Speak slowly, plainly. Say, "My name is..... I want to report a fire at....." Then wait to answer questions.

Conducting your

FIRE ESCAPE DRILL

Your home fire drill should not be scary. Make it a game for young children. In an emergency, they will follow directions. Instead of playfully hiding under a bed or in a closet. To be more realistic, pick a time when it's dark — if possible.

ALL SET? DRILL



- 1) Everyone in his or her bedroom - doors closed.
- 2) Sound the ALARM (possibly give a child the practice).
- 3) Everyone swings into action. Out of bed... to the door. Carefully test door before opening it.
FIRST DRILL: Escape through normal exit (hall or stairway).
SECOND DRILL: Imagine doors are hot — hall is blocked by fire!
Now, everyone must test his emergency escape exit. Depending on age and capability you need not actually go out on roof. BUT, be sure everyone can open windows and screens easily, position an emergency escape ladder quickly, etc.
- 4) Everyone gather at outside meeting spot. All accounted for?
- 5) Be prepared to carry out any duty assignments:
 - Notify Fire Department (know procedure)
 - Have special help for infants, elderly, third floor occupants — such as raising an outside ladder that is kept nearby.

Special Note: If caught in smoke and heat... **KEEP LOW.** Heat rises, so air is better closer to the floor. Take short breaths. Cover face with cloth.

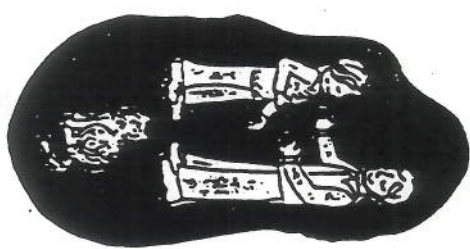

IN A FIRE ... Seconds Count!



HOME FIRE ESCAPE
GUIDELINE FOR
YOUR FAMILY

SAFE
Salem Area Fire Educators



HOME FIRE FACTS you should know . . .

HEAT RISES!

1,000-degree temperatures can travel far ahead of the actual flames.

Your normal escape path can quickly become a DEATH TRAP...when you open your bedroom door to escape. Your stairway and halls (first or second floor) can become filled with lung-scorching heat, poisonous fumes, and blinding choking smoke.

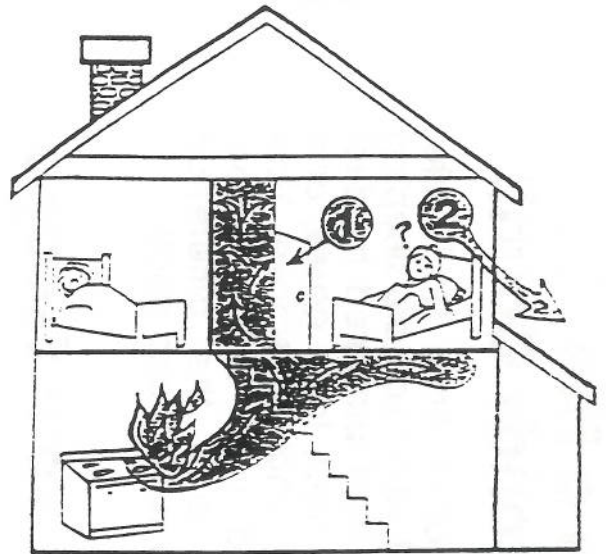

**YOU MUST PLAN TWO
ESCAPE ROUTES FROM
EVERY BEDROOM**

WHEN do most home fires start?

. . .between the hours of midnight and 6:00 a.m., just when you are ASLEEP. . .and least prepared!

WHERE do most home fires start?

. . .in this order: A) living room 37%, B) kitchen 22%, C) basement 14%, D) bedrooms 13%, E) all others 14%. See how most fires start just where they are likely to block your usual escape (from bedrooms).

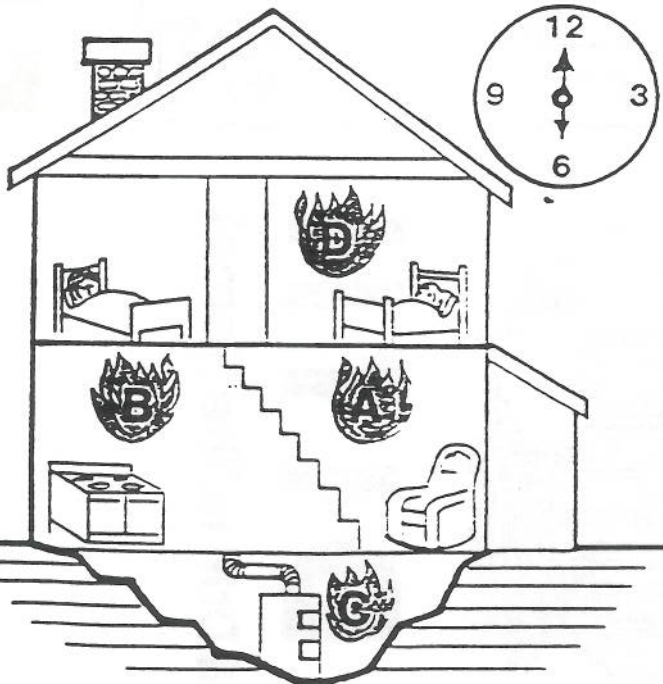

**YOU MUST PLAN TWO
ESCAPE ROUTES FROM
EVERY BEDROOM**

In a Fire . . . Seconds Count!

Most home fires start after midnight, when you are sleeping — and least prepared to deal with the heat, toxic gases, and blinding, choking smoke. How you and your children react could mean the difference between survival and death.

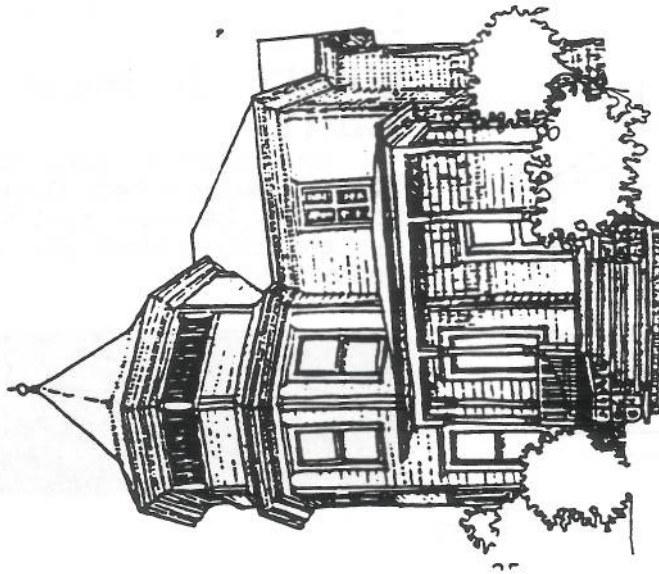

EDITH

(Exit Drill In The Home)

Practice Your Escape

Practice prevents panic during a fire emergency.

Plan Your Escape



1 Test your smoke detector. It can sound the alarm if there is smoke during the night so everyone will wake up and get out of the house.



2 Plan two ways out of every bedroom. Can you open your window? Can you safely reach the ground?



3 Crawl low in smoke, because the best air to breathe is near the floor.



4 Get out and stay out. Invisible toxic gases can kill you.



5 Plan a meeting place so you know everyone got out safely.



EDITH

(Exit Drill In The Home)

Look — My family could escape from a fire...easily. Safety is just a few feet away!

That attitude is exactly why most home fire deaths occur...in "ordinary homes" just like yours. They didn't think they needed a HOME FIRE ESCAPE PLAN — a fatal mistake!

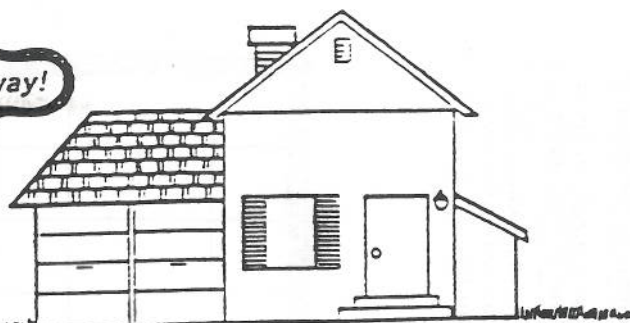

Here are true-life examples in Oregon:

OPEN BEDROOM DOORS, NO ESCAPE PLAN

Fire broke out at 12:20 a.m. (smoldering cigarette in sofa). Smoke and heat quickly spread down hall to three bedrooms. Two boys, ages 10 and 12, with bedroom door closed...escaped out window. Two other children, ages 4 and 6, with bedroom door left open...died of asphyxiation. The father, also with bedroom door open got to the bathroom before being overcome.

DELAYED ALARM, PANIC, NO ESCAPE PLAN

While watching the late show, faulty TV set wiring ignited curtains. The young mother tried to throw water on the fire. She died in the kitchen. Scorching heat and smoke quickly filled upstairs hall. The father was able to leap off porch roof to the ground. But their two children, ages 3 and 4, were suffocated at the foot of their bedroom window.

These mistakes cost 6 lives. It happened so easily — **SO NEEDLESSLY!** Why? Because these families (and yours?) did not have a simple **GUIDELINE FOR HOME FIRE ESCAPE!**

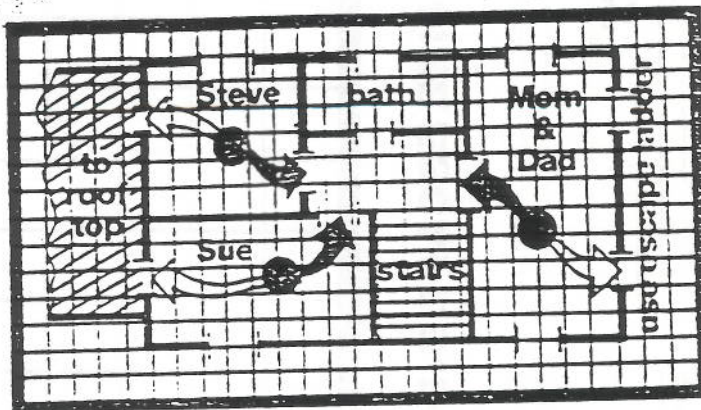

★ FIRE ESCAPE FLOOR PLANNING ★

Here's how to make a floor plan of ground or upper floor bedrooms...with **TWO ESCAPE ROUTES.**

STEP 1 (basic floor layout)

- Make an outline of entire floor area. Dimensions and details need not be exact.
- Now add each bedroom and label it.
- Locate windows, doors, and stairway as shown on above sample. If on upper floor, shade in any rooftops that could be used as a fire escape.

STEP 2 (room inspection)

- Go to each bedroom. Select the best window for an emergency escape.
- Test the window, screen, or storm sash to see that they work easily... and are large and low enough to use.

Step 3 (complete "Escape Plan")

- Black arrow shows normal exit through hall or stairway.
- Outlined arrows show emergency exit in case fire blocks hallway or stairs.

Be sure **EVERYONE** has an emergency escape route — bedroom second exit. If necessary, consider installing an escape ladder or rearranging bedrooms — children in rooms with easy rooftop escape or cutting access door between bedrooms — possibly through closet installing a hall door to separate bedrooms from rest house.

NOTE: If main hall door can be closed, all bedrooms can share the one best emergency escape exit.

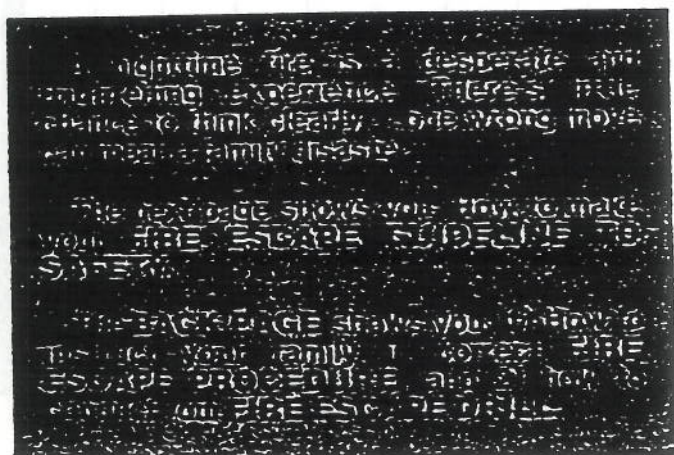

APPENDIX 2 & 3

**NFPA Conference
Cincinnati Ohio**

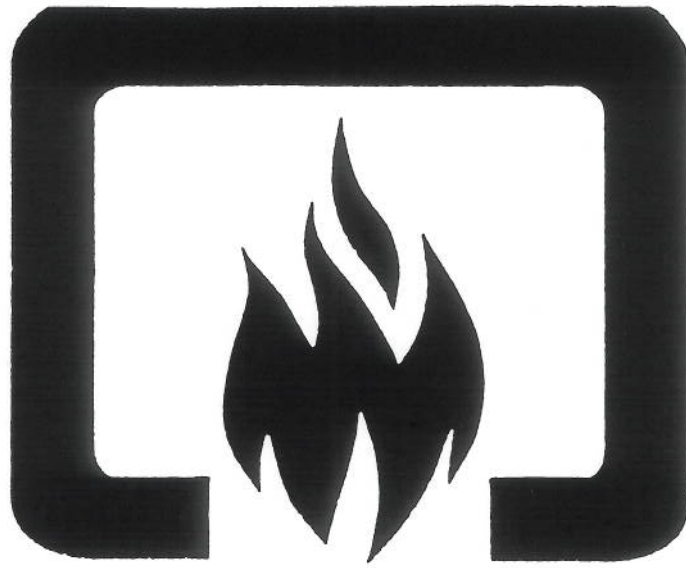

NFPA[®]

1998

ADA Area of Rescue Assistance

Presented by

**Dave Thompson
CORNELL Communications, Inc.**

**NFPA Booth # 898
May 17-19, 1998**

AREAS OF RESCUE ASSISTANCE

ADAAG 4.3.11



- **Scope & Design**
- **Egress & Life Safety During an Emergency**
- **Barriers to Handicapped — Barriers to All**
- **Where / When Required**
- **Signage**
- **Communications**
- **Design of Area**
- **Summary**

Barriers to the Handicapped Are Barriers to All!

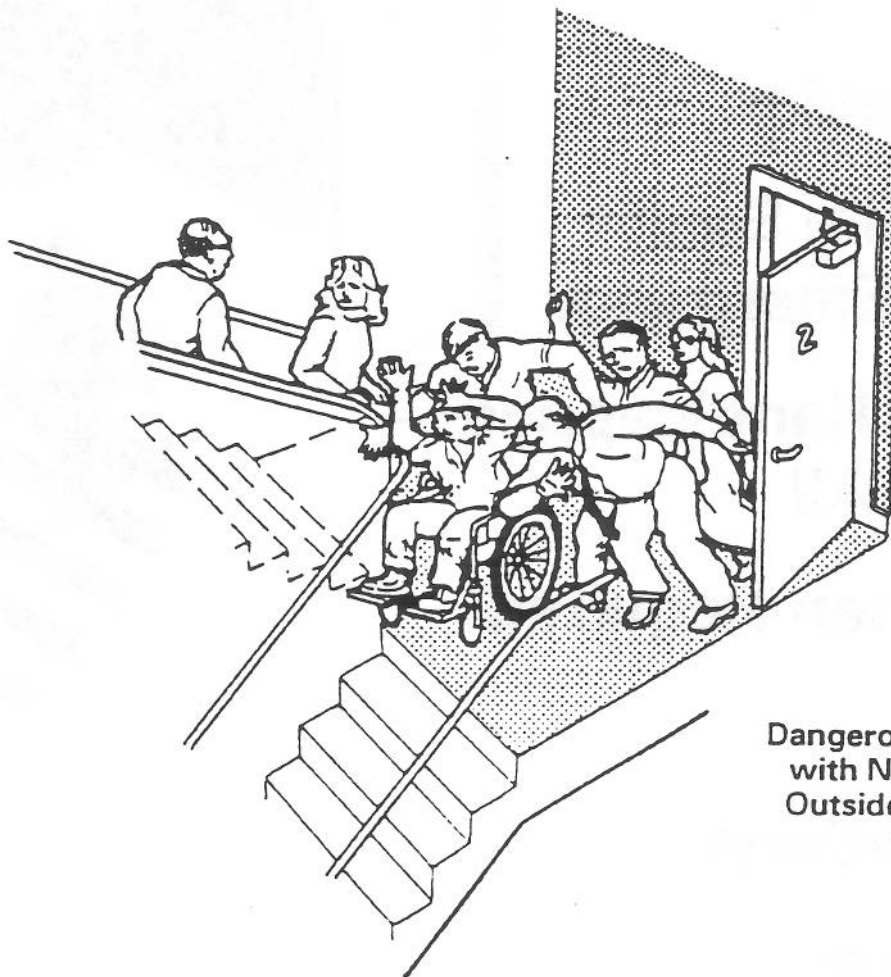

Dangerous Exit Stairway
with No Waiting Area
Outside Path of Travel

Signage

- Room Identification Signs



- Directional Signs



- Instruction Signs

Where and When. . .

What's Practical? — You Decide

Required:

- Upper Floors
- Single Story Buildings and Ground Floors Maybe ?
- Basement Level ?
- Federal vs. State vs. Local Codes

Not Required:

- Automatic Sprinkler System
- Building with Horizontal Exits

Communications

CORNELL Rescue Assistance Series 4200

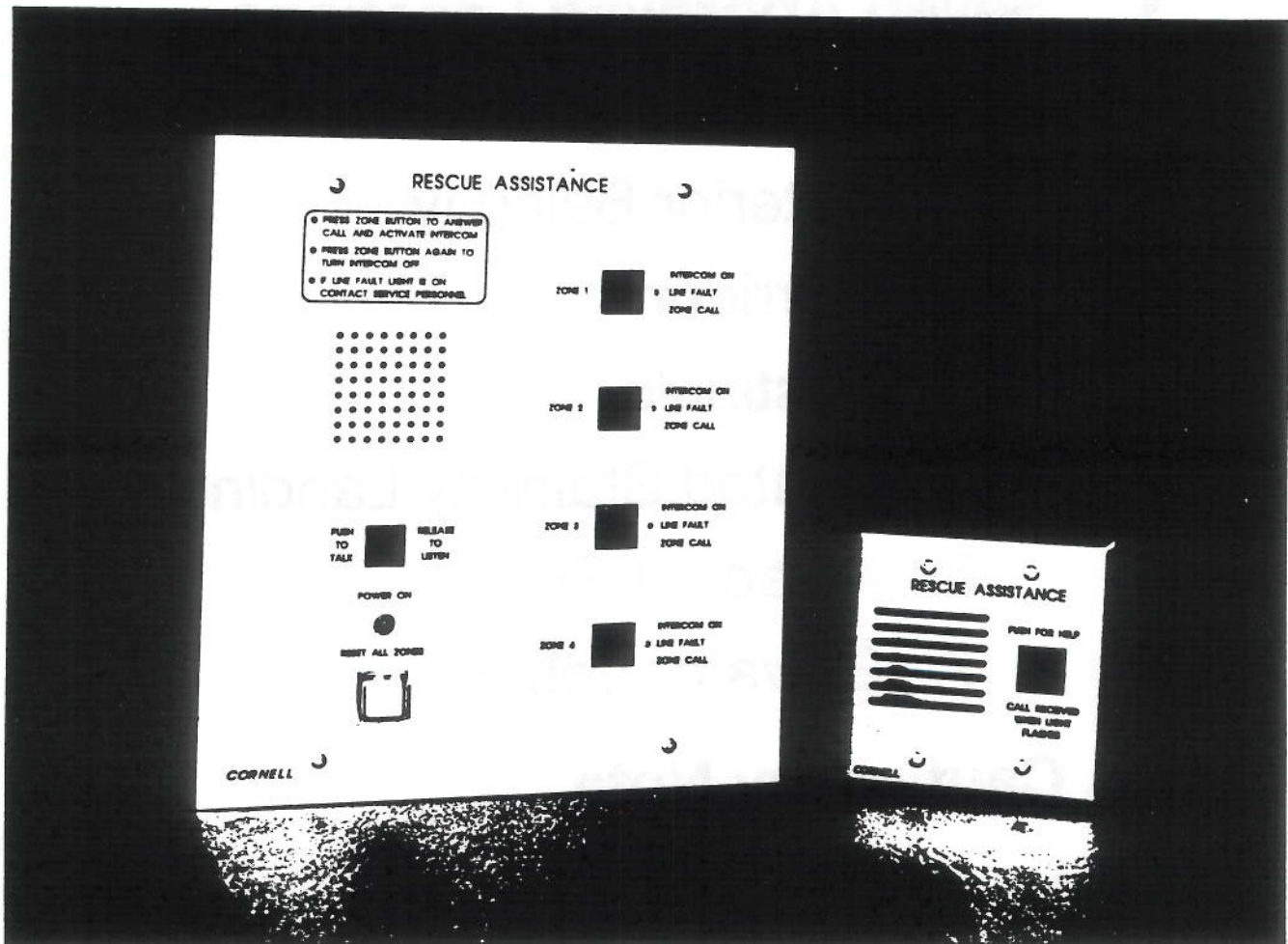

Master Station

Call Station

Design of Area

- **Exit Stairway Dimensions**
- **Approved Locations**
- **Seven Approved Locations**
 1. Stairway
 2. Exterior Balcony
 3. Corridor
 4. Vestibule
 5. Vented Stairway Landing
 6. Adjacent Room
 7. Elevator Lobby
- **Cautionary Note**

Summary

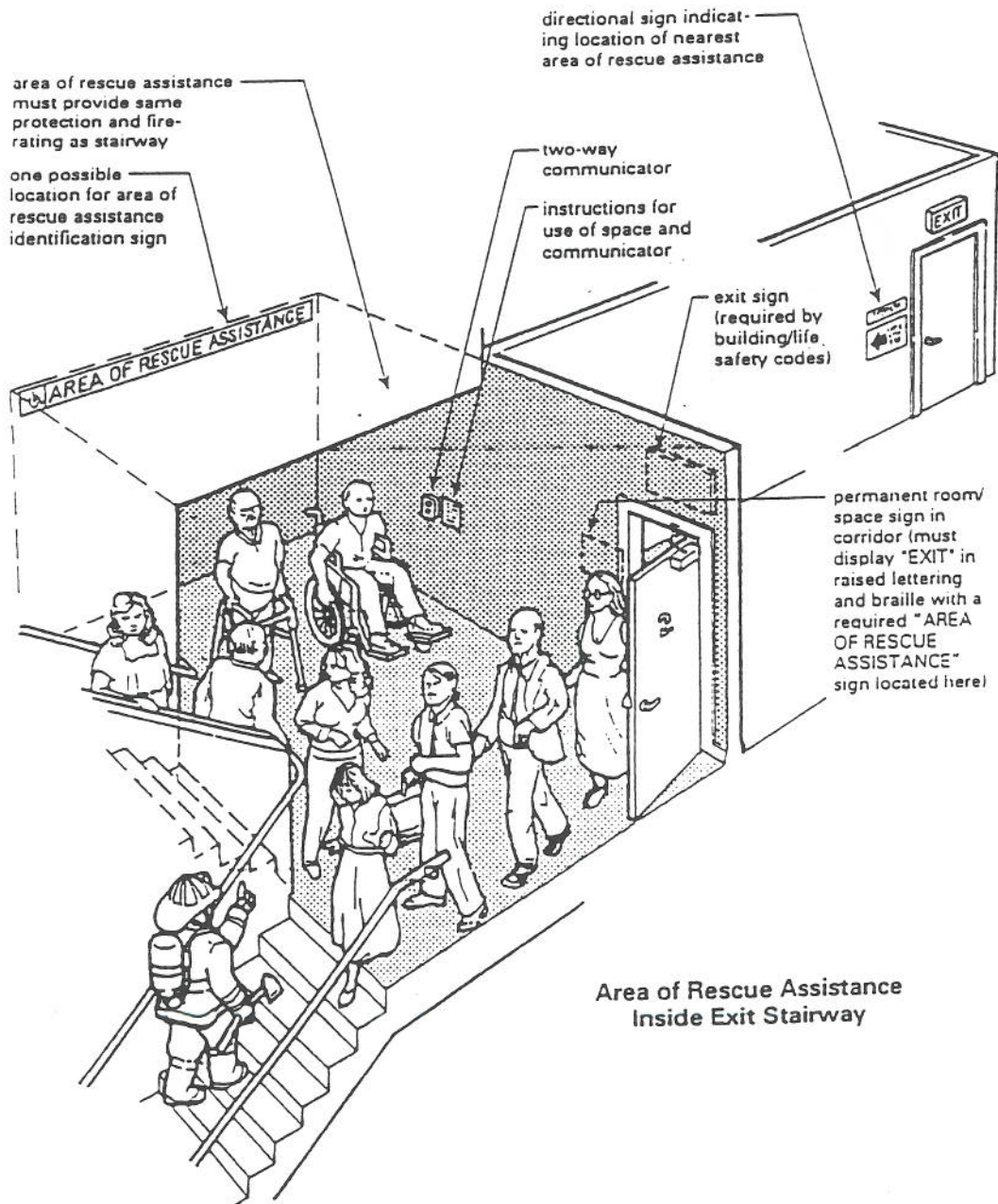

- Consider *CORNELL* as your source and resource for Areas of Rescue Assistance.

Example Fire & Life Safety System

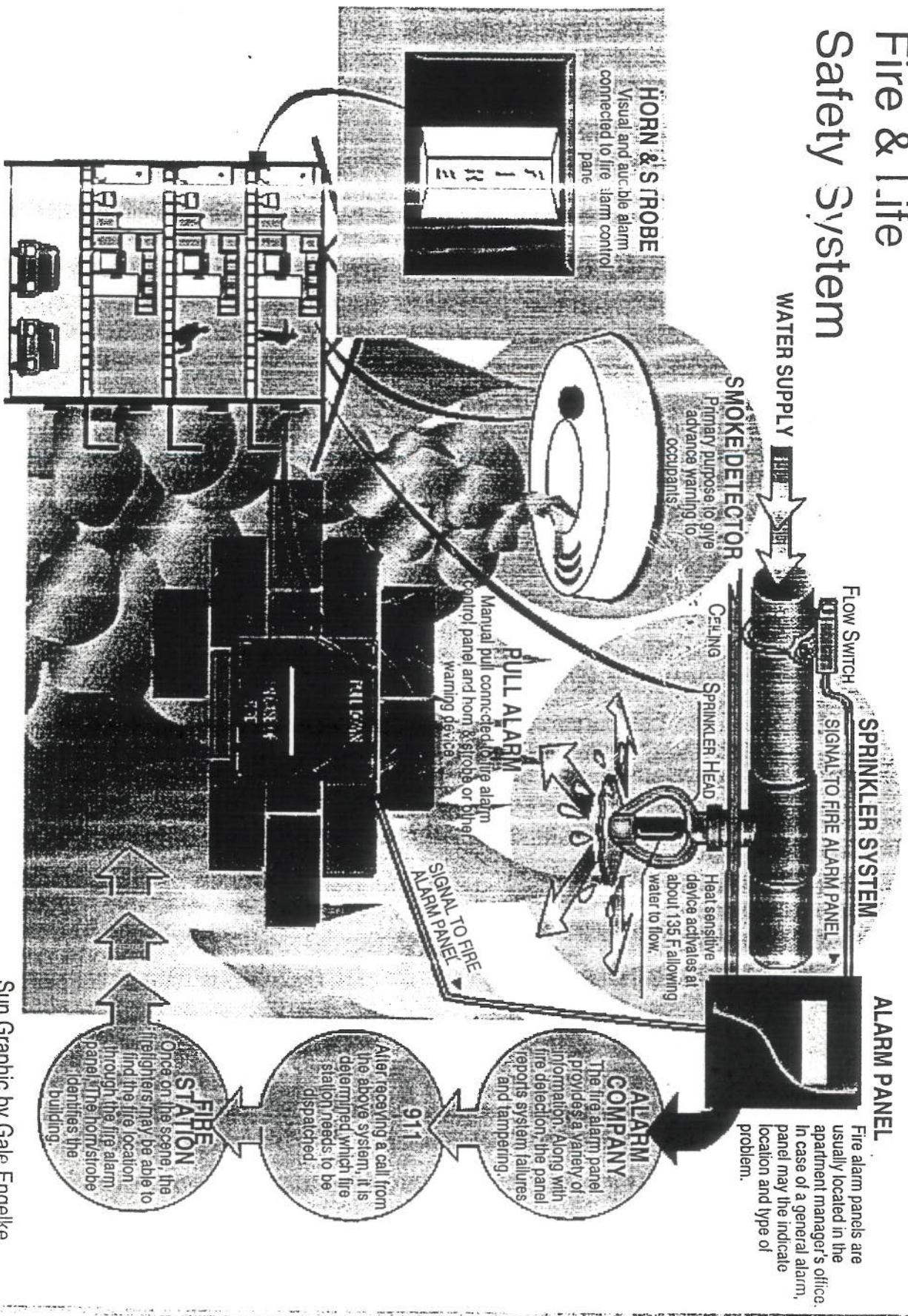

Sun Graphic by Gale Engelke

CORNELL
Communication Solutions

Rescue Assistance Systems



A.D.A. Information

- Tech Sheets
- Demo Outline
- Architect C.E.U. Data
 - Bulletins

AREAS OF RESCUE ASSISTANCE

ADAAG 4.3.11



This Tech Sheet is part of a series of publications on the design requirements of the ADA Accessibility Guidelines (ADAAG). This issue provides scope and design information on the requirements for areas of rescue assistance. Although based on the ADAAG requirements, the information provided on the following pages is advisory and should be considered as supplemental to the ADAAG. The ADAAG must be consulted for specific requirements for areas of rescue assistance.

Design for people of all ages and all abilities

BARRIER free ENVIRONMENTS

Incorporated

Compliments of:

CORNELL
Communication Solutions

1-800-558-8957

the Americans with Disabilities Act Accessibility Guideline Tech Sheet Series

CONTENTS

Introduction	1
ADAAG Requirements for Areas of Rescue Assistance	4
Design Specifications for Areas of Rescue Assistance	7
Size of Areas of Rescue Assistance	7
Signage Identifying Areas of Rescue Assistance	8
Communication with People in Areas of Rescue Assistance	11
Design of the Exit Stair at Areas of Rescue Assistance	12
Approved Locations for Areas of Rescue Assistance	14
ADAAG Reference Index	22

Barrier Free Environments, Inc. is authorized by the National Institute on Disability and Rehabilitation Research (NIDRR) to develop information and materials on the Americans with Disabilities Act (ADA). However, you should be aware that NIDRR is not responsible for enforcement of the ADA. The information, presented here is intended solely as informal guidance, and is neither a determination of your legal rights or responsibilities under the Act, nor binding on any agency with enforcement responsibility under the ADA.

To obtain additional copies of this Tech Sheet, contact your Disability and Business Technical Assistance Center. To be automatically connected to your regional center, call 1-800-949-4ADA. Portions of this Tech Sheet may be copied as many times as desired by the Disability and Business Technical Assistance Centers for distribution to small businesses but may not be reproduced in whole or in part or sold by any other entity without written permission of the authors.

Introduction

Egress and life safety during an emergency are major concerns for all building occupants. For people with disabilities the problems of evacuating a building are a greater concern. Many people with mobility impairments cannot use stairs and people with hearing and vision impairments cannot receive emergency notification and directions unless they are provided in both audible and visual forms which accommodate various methods of assimilating information.

For buildings of more than one story emergency exits usually are provided at stairways. In emergency situations elevators generally cease operation, making the stairway the only path available to leave a multi-story building. In most cases stairways are designed to provide a safe means of isolating building occupants from smoke and fire. Once the stairway is entered, people are protected from heat and smoke until they reach the ground floor and safety.

People who have difficulty using stairs or who use wheelchairs or scooters do not have the same access to a safe means of exiting a building as people who can climb stairs. Exit stairways seldom have additional floor space where people can stand or park a wheelchair on the landing while they await assistance. If people using wheelchairs attempt to remain on the small landings that are typically provided, they restrict the path down the stairs for other people as well as jeopardize their own safety.

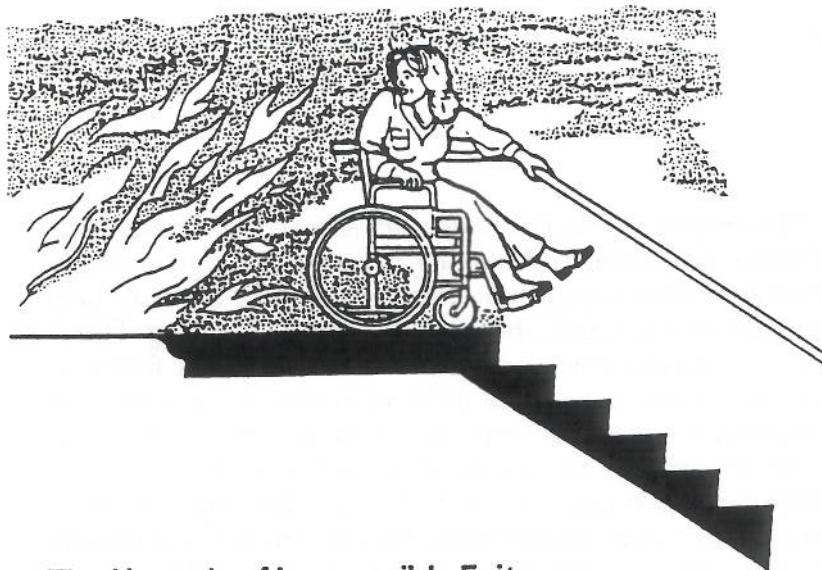

The Hazards of Inaccessible Exits

The Americans with Disabilities Act Accessibility Guidelines (ADAAG) was published as the Standards for Accessible Design in Appendix A in the Department of Justice's Final Rule, 28 CFR Part 36/Nondiscrimination by Public Accommodations and in Commercial Facilities. Copies of the Final Rule may be obtained by calling the Department of Justice at 1-800-514-0301 or the Access Board at 1-800-US-1-ABLE (1-800-872-2253).

Sidebars contain quotations from ADAAG and from other federal documents.

BFE note:

The term "stairway" is used in the ADAAG and will be used throughout this Tech Sheet. In common building practice the term "stairway" is defined as one or more flights of stairs and the necessary landings and platforms connecting them, to form a continuous and uninterrupted passage from one story to another in a building or structure.

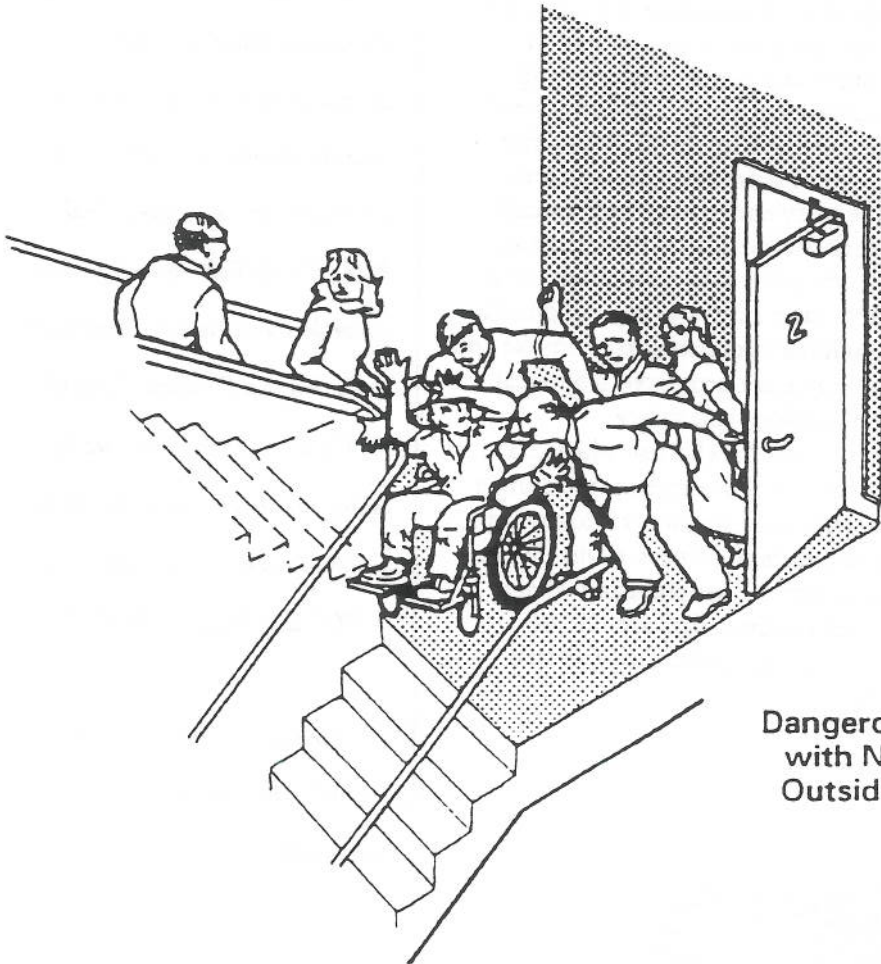

**Dangerous Exit Stairway
with No Waiting Area
Outside Path of Travel**

ADAAG 3.5 Definitions.

Area of Rescue Assistance. An area, which has direct access to an exit, where people who are unable to use stairs may remain temporarily in safety to await further instructions or assistance during emergency evacuation.

The Americans with Disabilities Act Accessibility Guidelines (ADAAG) require that a safe waiting area be provided at or near inaccessible exits for people who cannot climb stairs to remain until rescue personnel can assist them in evacuating the building. These spaces, or areas of rescue assistance, must be a designated fire protected area (approved by a local building authority) that is within or immediately adjacent to an exit stairway. Areas of rescue assistance must be large enough for, at a minimum, two wheelchair users to position themselves out of the path of travel. They must also be equipped with a two-way communication system and have adequate signage that directs building occupants to the protected location. Areas of rescue assistance must be on an accessible route complying with all the requirements of ADAAG 4.3 Accessible Route.

AREAS OF RESCUE ASSISTANCE

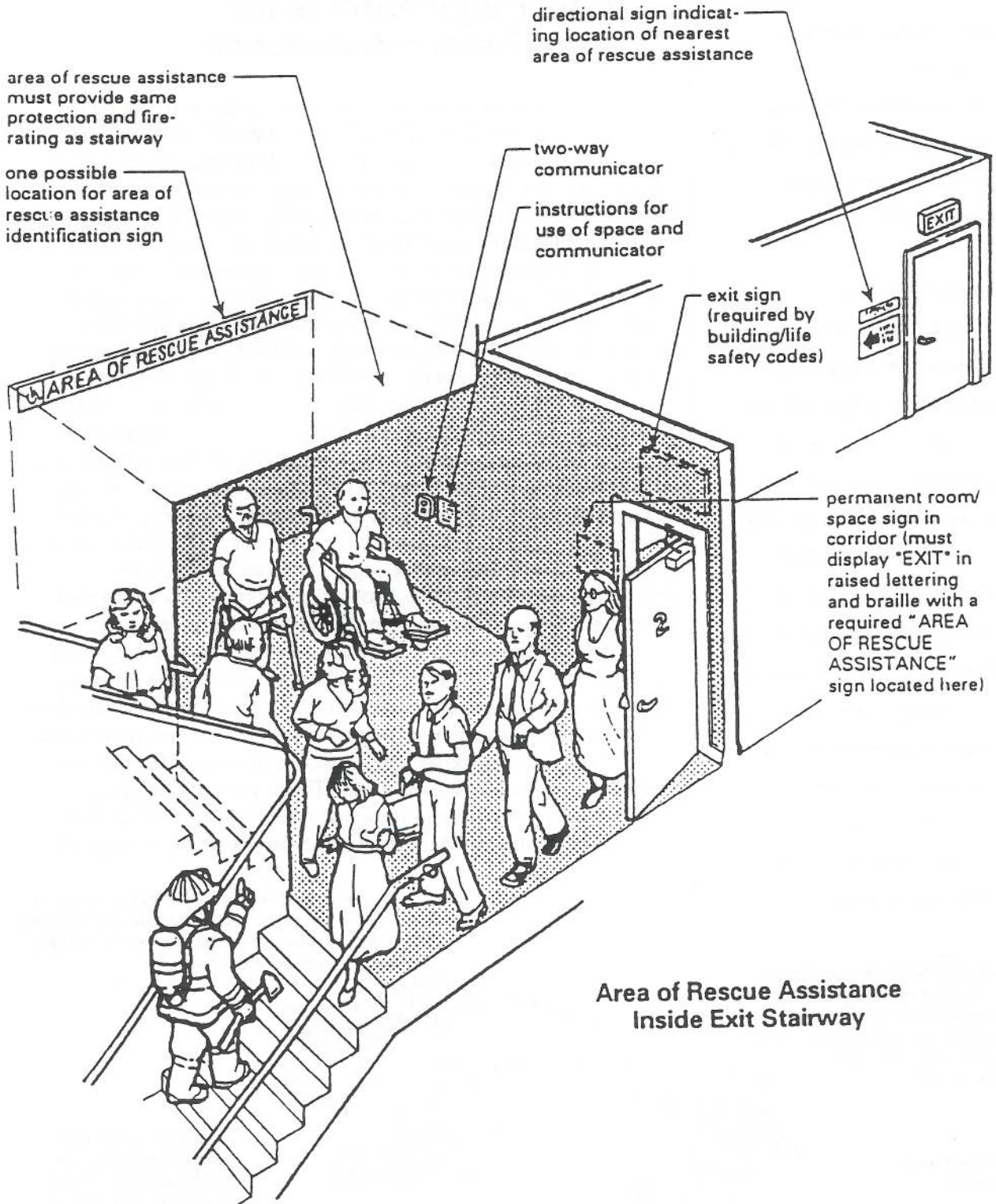

**Area of Rescue Assistance
Inside Exit Stairway**

BFE note:

Area of Rescue Assistance Are Required Only in New Buildings. Under ADAAG a new building is a structure that

- *had its last building permit application after January 26, 1992 and*
- *was first occupied after January 26, 1993.*

ADAAG 3.5 Definitions.

Means of Egress. A continuous and unobstructed way of exit travel from any point in a building or facility to a public way. A means of egress comprises vertical and horizontal travel and may include intervening room spaces, doorways, hallways, corridors, passageways, balconies, ramps, stairs, enclosures, lobbies, horizontal exits, courts and yards. An accessible means of egress is one that complies with these guidelines and does not include stairs, steps, or escalators. Areas of rescue assistance or evacuation elevators may be included as part of accessible means of egress.

ADAAG Requirements for Areas of Rescue Assistance

The requirements for areas of rescue assistance are found in two sections of the ADAAG: 4.1.3 (9) Accessible Buildings: New Construction and 4.3.11 Areas of Rescue Assistance. Section 4.1.3 (9) known as the "scoping" provision, specifies where and when areas of rescue assistance must be provided. Section 4.3.11 provides the technical specifications for the design of the designated area.

Areas of rescue assistance are required in all new multi-story buildings (and additions, which are considered new construction) covered by the ADAAG. Some exceptions are permitted and will be detailed below. Existing buildings, including those undergoing alterations, are not required to have areas of rescue assistance.

ADAAG 4.1.3 (9) specifies that an "... accessible means of egress shall be provided in the same number as required for exits by local building/life safety regulations." An accessible "means of egress" is a path of travel accessible to people with disabilities that allows them to reach a safe area out-of-doors or in another building protected by a firewall. When this accessible route on floors above and below the ground floor cannot discharge (open) onto an accessible route at grade, then each inaccessible floor must be provided with areas of rescue assistance in the same number as the required exits.

In multi-story buildings exit stairways are part of the required means of egress. In new buildings without an automatic sprinkler system, areas of rescue assistance must be placed in or adjacent to exit stairways (one exception is allowed, see page 21) so rescue personnel can get to the stranded person quickly from a stairway or smokeproof elevator to assist in their evacuation. There are seven acceptable locations for areas of rescue assistance specified in ADAAG. Each of these will be described in this Tech Sheet starting on page 14.

areas of rescue assistance may be required at ground floors and in single story buildings where required exits do not discharge or open onto an accessible route at grade level

fire-rated walls and doors

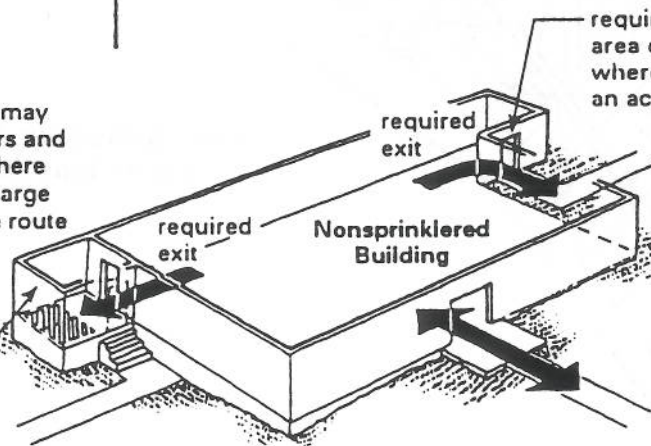

main entrance and one of the required exits: entrance must be accessible, on an accessible route, and provide accessible egress

Areas of Rescue Assistance May Be Required in Some One - Story Buildings

AREAS OF RESCUE ASSISTANCE

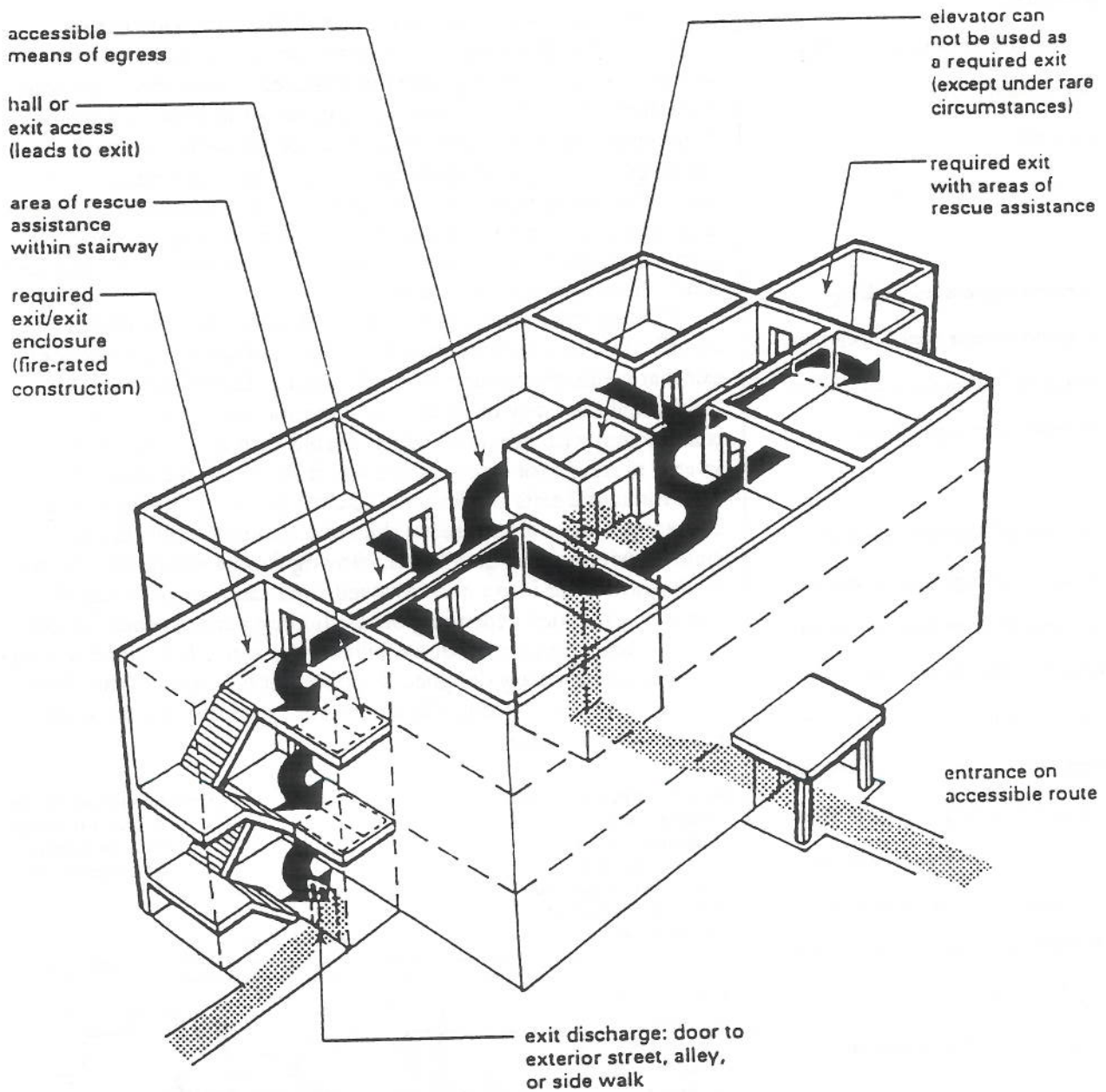

Accessible Means of Egress As Part of Accessible Route

BFE note:

Areas of rescue assistance are not required

- *if supervised sprinkler system is installed,*
- *or if horizontal exit meeting local building code requirements is present,*
- *or in existing buildings.*

If horizontal exits allow building occupants to move from a dangerous area of the building to a safe (refuge) area without changing levels.

The scoping provisions in 4.1.3: Accessible Buildings: New Construction "for areas of rescue assistance do not apply to exterior facilities covered by 4.1.2 [Accessible Sites and Exterior Facilities]. For example, parking lots and open parking garages are covered only by 4.1.2 and are not required to ... [have] areas of rescue assistance." [36 CFR Part 1191, Federal Register, July 26, 1991 (Access Board's Final Guidelines)]

"Scope is a set of directives that states "where", "when", and "how many" elements and spaces must be accessible and comply with the design requirements of the ADAAG.

When Areas of Rescue Assistance Are Not Required

Only under two circumstances are multi-story buildings (or single story buildings with insufficient numbers of required exits with accessible routes to grade) not required to have areas of rescue assistance. The first is if a new building has a supervised automatic sprinkler system monitored 24 hours a day. However, even in buildings equipped with sprinkler systems it is recommended that areas of rescue assistance be provided. It is quite possible for a person with a disability to be stranded and overcome with smoke before rescue personnel could reach him/her, given the difficulty in locating someone in a smoke-filled building.

The second instance where the areas of rescue assistance as described in 4.3.11 are not required is in a building with a horizontal exit that meets the requirements of a local building authority. Horizontal exits may be formed by continuous fire-protected construction with fire doors which enable each area to serve as an area of refuge (or rescue assistance) from fire in the other area.

Horizontal exits are designed to allow people to move from a dangerous area to a safe area in the same building or an adjacent building without changing levels. Moving from a fire-involved zone on the same floor into a non-involved zone can provide refuge for one or more hours, depending on the building construction. Most people, including those with disabilities, can move from zone to zone through appropriately designed fire doors. It is best to consult local building authority or code officials on approved use of horizontal exits within your area.

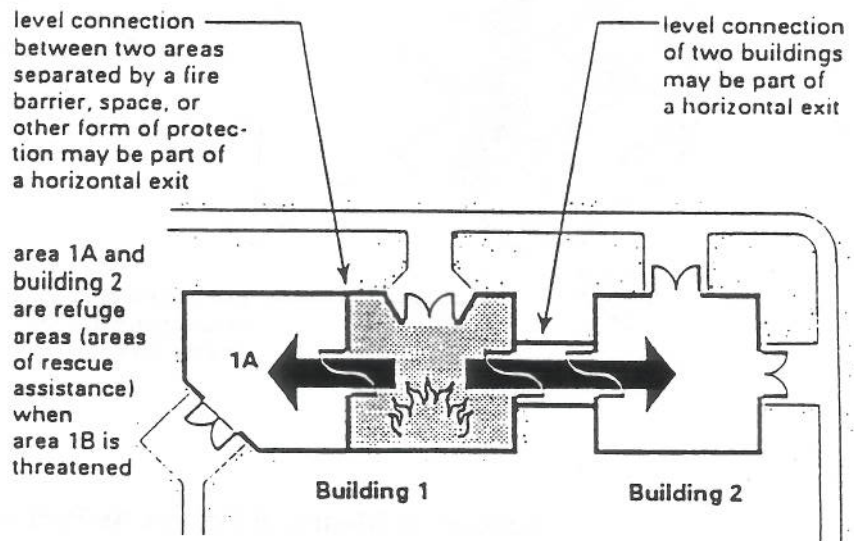

A Horizontal Exit Can Meet the Requirement for Areas of Rescue Assistance

Design Specifications for Areas of Rescue Assistance

Notes in italic are recommendations.

permanent room/space sign in corridor (must display "EXIT" in raised lettering and braille with a required "AREA OF RESCUE ASSISTANCE" sign located here)

exit sign in corridor (required by building/life safety codes)

it is recommended that all features and elements within all areas of rescue assistance be identical throughout the building

communicator (with use of space instructions adjacent) located within reach range of a seated user

possible location for identification sign

area of rescue assistance with the same fire rating as stair enclosure

minimum of two wheelchair parking spaces

stair must have 48 inches clear width between handrails

Elements of Area of Rescue Assistance

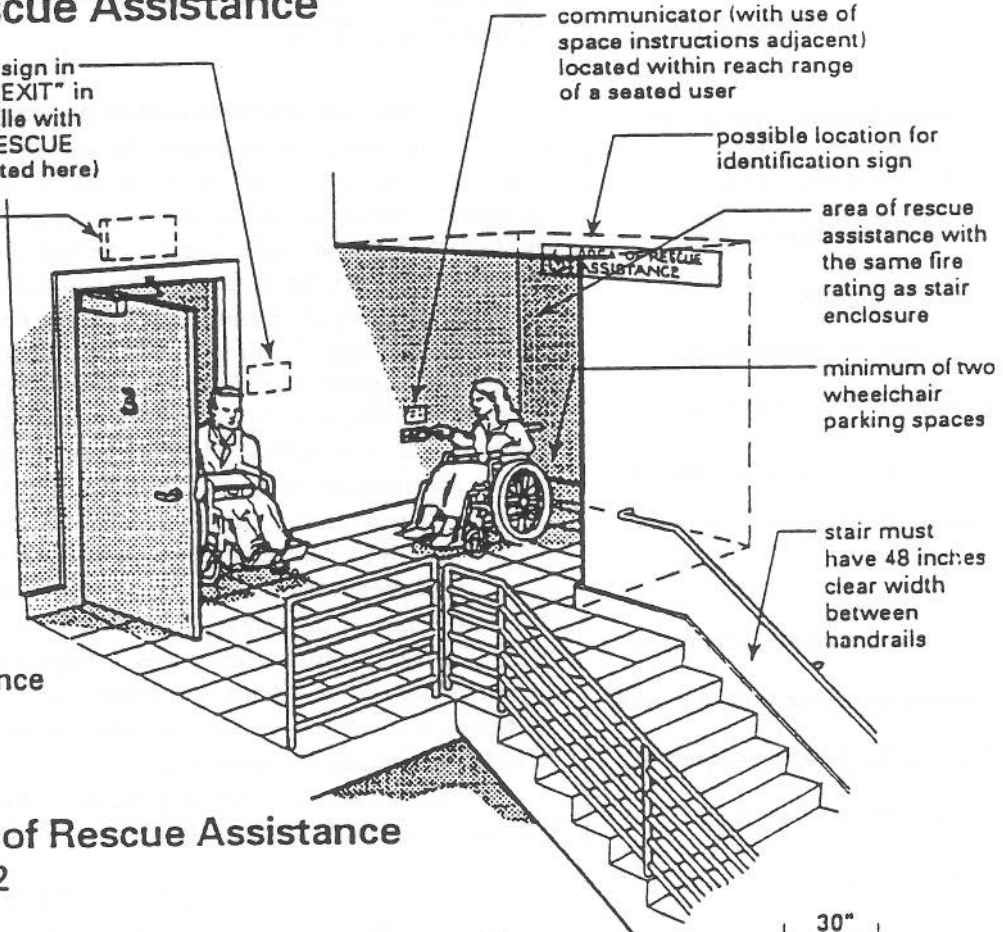

Size of Areas of Rescue Assistance ADAAG 4.3.11.2

The area of rescue assistance must be located on an accessible route and be large enough to permit at least two people using wheelchairs to enter the space and position themselves outside the exit path of other building occupants. This necessitates that at least two 30 inch by 48 inch wheelchair parking spaces be provided within the area of rescue assistance. Where the "parking space(s)" are not recessed into an alcove, the area for wheelchair users to position themselves could be indicated by a change of floor material or floor marking.

Local building authorities may reduce the required number of spaces per floor to one where the calculated occupant load per floor is less than 200. In large occupancy buildings some floors may be required to have more than two parking spaces in a single area of rescue assistance.

It is critical for the safety of all building occupants that the accessible route to, and the area of rescue assistance itself, be continually available. Areas of rescue assistance must never be used for temporary storage, even of lightweight movable items. Maintenance staff must be cautioned not to place extra furniture, cleaning equipment, or other items in this "out of the way" corner.

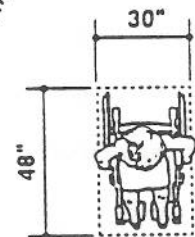

Clear Floor Space for Parking a Wheelchair

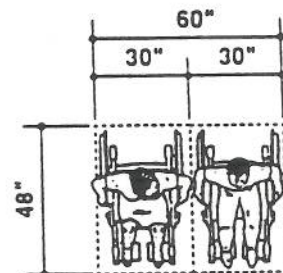

Two Wheelchair Parking Spaces

Signage Identifying Areas of Rescue Assistance ADAAG 4.3.11.5

Signs which designate permanent rooms and spaces must be

- *in raised type and Braille*

(ADAAG 4.30.4),

■ *of appropriate finish and contrast (ADAAG 4.30.5), and*

■ *mounted at appropriate location and height (ADAAG 4.30.6).*

Signs which provide direction to, or information about, functional spaces of the building must have appropriate

- *character proportion*

(ADAAG 4.30.2),

- *character height*

(ADAAG 4.30.3), and

- *finish and contrast*

(ADAAG 4.30.5).

When room identification is to be provided in a building then ADAAG requires the installation of a sign that identifies the designated space for the area of rescue assistance. Signs used to indicate permanent rooms and spaces are required by ADAAG to be tactile and mounted at a particular location beside doors so people with visual impairments can find a specific room or area.

Although areas of rescue assistance may be considered permanent spaces in a building, the signage identifying them is not subject to the ADAAG signage specifications of mounting height, location, or tactile lettering that is required for other permanent rooms and spaces. Under the ADAAG 4.1 Minimum Requirements, these signs are not required to be tactile because it is generally assumed that areas of rescue assistance are used primarily by people with mobility impairments who cannot climb stairs. However, a person with a visual impairment may also have balance problems or a condition that limits stamina that prevents them from walking rapidly down stairs. This person may have to seek refuge in an area of rescue assistance also. Thus, where exit doors lead to an area of rescue assistance, it is recommended that tactile signage complying with ADAAG be installed at the exit door.

Only one sign identifying the area of rescue assistance is required and it must meet the following ADAAG specifications:

- contain the words "AREA OF RESCUE ASSISTANCE" in uppercase type
- display the International Symbol of Accessibility
- be illuminated when exit sign illumination is required (by other codes)
- comply with ADAAG for character proportion, height, finish, and contrast



these signs must be illuminated if exit signs are required to be illuminated

Sign Identifying Area of Rescue Assistance

AREAS OF RESCUE ASSISTANCE

Signage Placement and Size. The required sign identifying the area of rescue assistance should be located in a standard, logical, and predictable place at the entrance to, as well as inside, over, or adjacent to the actual area of rescue assistance. It should be positioned where good visibility is maintained at all times.

Any one of the suggested locations for the required signage shown in the illustration may be a good choice. Characters on signs identifying areas of rescue assistance must be sized according to the viewing distance from which they are to be read. If the sign is 80 inches or greater above the floor the minimum character height is three inches (ADAAG 4.30.3).

overhead locations are good because the sign can be seen over the heads of moving people

if overhead location is used letter size must be 3" minimum

Possible Locations for Required Sign at Areas of Rescue Assistance

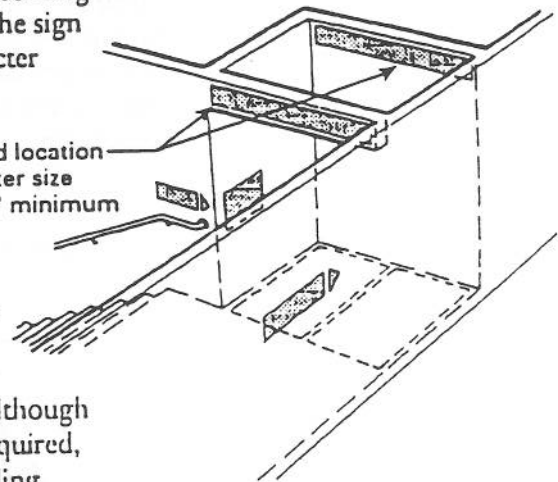

Directional Signage to Areas of Rescue Assistance. Although only one sign identifying the area of rescue assistance is required, additional directional signs may be required to guide building occupants to protected areas. If, for example, the accessible route passes through an intermediate door before arriving at the area of rescue assistance, an additional directional sign at the door would help users quickly find the safe area.

Notes in italic are recommendations.

"EXIT" sign required by building/life safety codes

a sign positioned at locations 1, 2, or 3 can help to guide the user to the area of rescue assistance – such signs are not required by the ADAAG but if installed they must meet the ADAAG requirements for character proportion and height as well as finish and contrast

when exit signage is provided, ADAAG requires an exit sign (in raised lettering and Braille)

if sign identifying area of rescue assistance is installed here, it is recommended that it be tactile

Possible Locations for Additional Optional Directional Signs Indicating Route to Area of Rescue Assistance

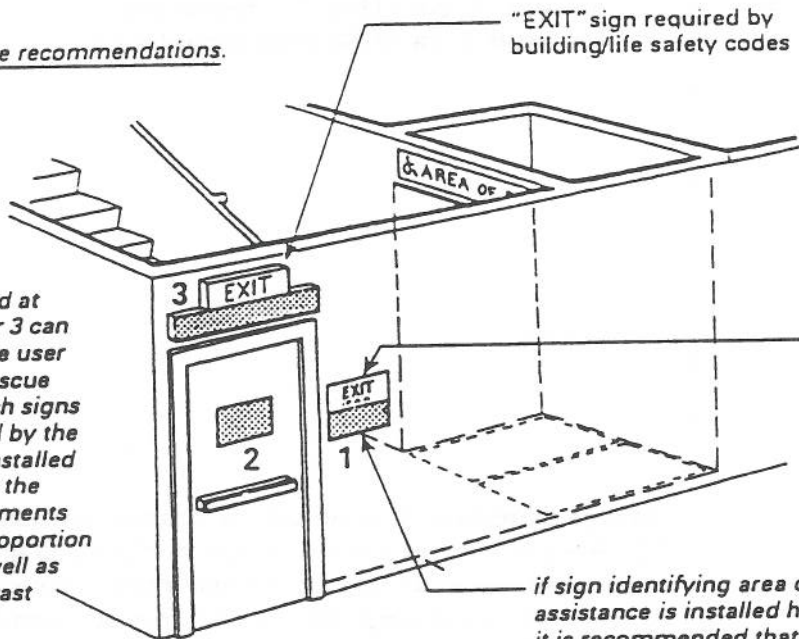

Additional directional signage may need to be installed at corridor intersections and at other building fire safety signage to ensure the safe evacuation of building occupants with disabilities and should be considered for any signage system. If an area of rescue assistance is not directly accessed by a designated exit door then a directional sign must be installed at the door to indicate the direction to the nearest area of rescue assistance.

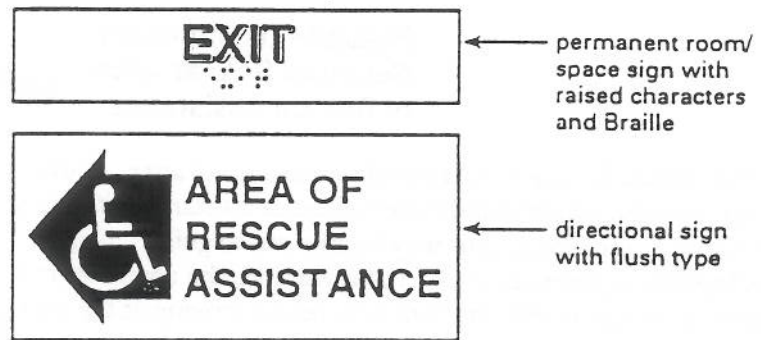

Sign Directs User to Remotely Located Area of Rescue Assistance

ADAAG 4.3.11.5 Identification ... Signage shall also be installed at all inaccessible exits and where otherwise necessary to clearly indicate the direction to areas of rescue assistance.

See also ADAAG 4.1.3 (16) Building Signage, and 4.30 Signage

Signage Describing Use of Area of Rescue Assistance. ADAAG also requires that instructions on the use of the area of rescue assistance under emergency conditions be posted adjoining a two-way communication system. This may be a separate sign subject to the requirements of directional/information signage or this information may be incorporated into the communication panel itself. Communication with people in areas of rescue assistance is presented in the next section.

Communication with People in Areas of Rescue Assistance ADAAG 4.3.11.4

A method of two-way communication with both visible and audible signals must be provided in each area of rescue assistance. The system must permit non-verbal use so someone with a hearing or speech impairment could notify the control center of his or her presence and be assured that someone is on the way.

Simple visual panels can be installed that have separate lights indicating that various messages have been received and what the response will be. Other non-verbal communication panels may use LEDs or screen displays to permit visual messages to be sent by the control center managing the evacuation. The communicator must be powered by the facility or building emergency electrical service to ensure continued operation during emergencies.

Buttons, operating mechanisms to signal for help or to reply, and the location of the unit itself must be within the reach range of a seated person. The communication panel must be located no higher than 48 inches above the finished floor for a forward reach and 54 inches for a side reach and must be operable without tight grasping or twisting. Instructions for operating the two-way communication system, if they are not part of the panel itself, must be placed adjacent to the unit inside the area of rescue assistance.

Communicators must comply with ADAAG 4.27 Controls and Operating Mechanisms, 4.2.5 Forward Reach, and 4.2.6 Side Reach.

ADAAG 4.3.11.4 Two-way Communication... visible signal requirement could be satisfied with something as simple as a button in the area of rescue assistance that lights, indicating that help is on the way, when the message is answered at the point of entry.

Notes in italic are recommendations.

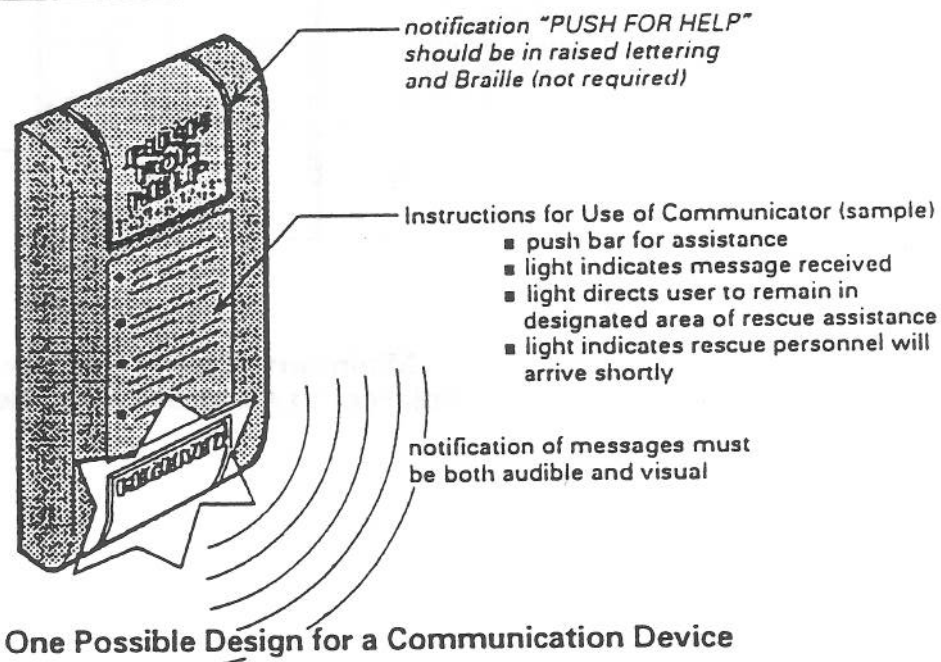

Design of the Exit Stair at Areas of Rescue Assistance ADAAG 4.3.11.3

Exit stairs adjacent to areas of rescue assistance must be sufficiently wide to allow someone to be carried down the stairs in a controlled descent evacuation chair or in his/her own wheelchair and at the same time allow a walking person to pass. The minimum width space in which this can be safely performed is 48 inches; therefore ADAAG specifies a minimum stairway width of 48 inches between handrails. Local building codes usually specify landing depth and base it upon the stair width. Exit stairs under ADAAG are 48 inches wide minimum, and although some state building codes allow less, the depth of the landing should be 48 inches minimum also.

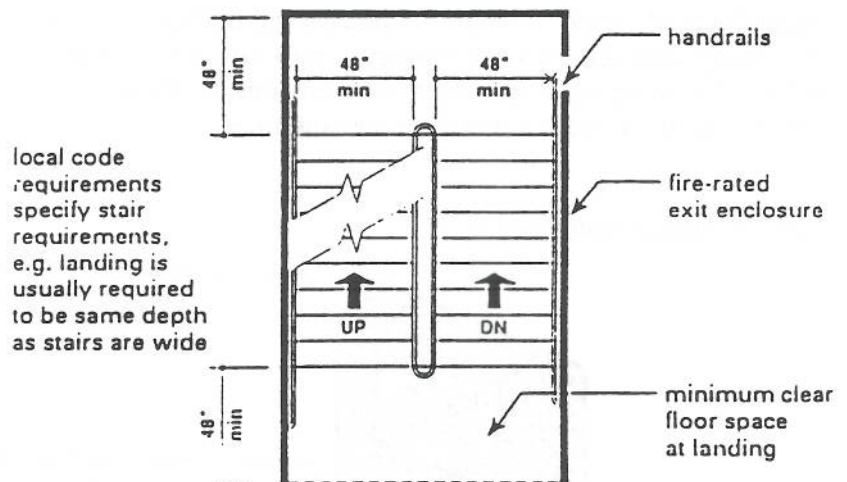

Minimum Requirements for Stair Adjacent to Areas of Rescue Assistance

In addition to the "fireman's carry" other methods of assisting a person to evacuate a building are available. Controlled descent chairs fold and can be placed in exit stairs for use in emergencies. Through friction braking systems, rollers, and other devices these chairs allow a relatively small person to take a larger person down the stairs with safety. It is recommended that at least certain designated building occupants familiarize themselves with (or be instructed in) the use of such a device. Controlled descent chairs are of no use for people who cannot transfer into them at the top of the stairs. Don't forget to have the person's wheelchair brought down to the exit discharge area.

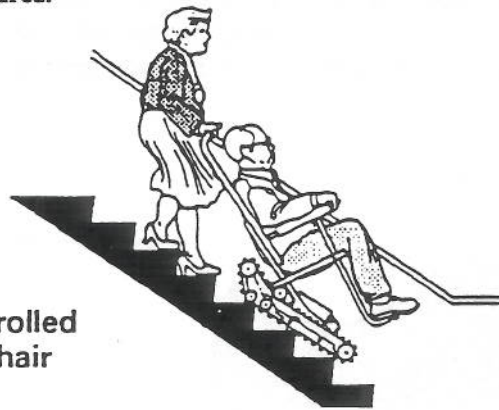

Use of Controlled Descent Chair

For people in wheelchairs several rescue personnel must be prepared to carry the individual down the exit stairs. This should not be attempted by people not trained for the task and is usually only possible when the person is in a manual wheelchair. If the person is in a heavy powered wheelchair he/she will probably have to be carried down separately from his/her chair.



Rescue Personnel Assisting Person in Manual Wheelchair

A.4.3.10 Egress. Because people with disabilities may visit, be employed or be a resident in any building, emergency management plans with specific provisions to ensure their safe evacuation also play an essential role in fire safety and life safety.

Approved Locations for Areas of Rescue Assistance ADAAG 4.3.11.1

An area of rescue assistance must be on an accessible route and must be easy for building occupants to reach. It must be located in one of seven approved locations connected or adjacent to an exit stairway. A pressurized elevator lobby is the only situation where an area of rescue assistance is not required to be at or near a stairway. It is important to note that all fire rating requirements and locations for protected spaces are subject to local code authority approval.

Cautionary Note: An area of rescue assistance, even when protected with fire-rated walls, does not ensure that an occupant will be safe for an hour. At best, most of the areas of rescue assistance provide an additional ten to fifteen minutes for a building occupant to remain until rescue personnel arrive. It is not meant to be an area of safe refuge where a person can remain for any extended period of time.

Notes in italic are recommendations.

in fire-rated corridor, fire-rated construction also around entire area of rescue assistance

identification signage may be mounted in either location, it is recommended that both signs be installed

instructions for use of space

two-way communication system

minimum one hour fire-rated corridor serves as accessible route and path of travel to exit

emergency personnel will use stairway to assist with evacuation

exit enclosure

permanent room/space signage

3'-0" minimum width accessible route

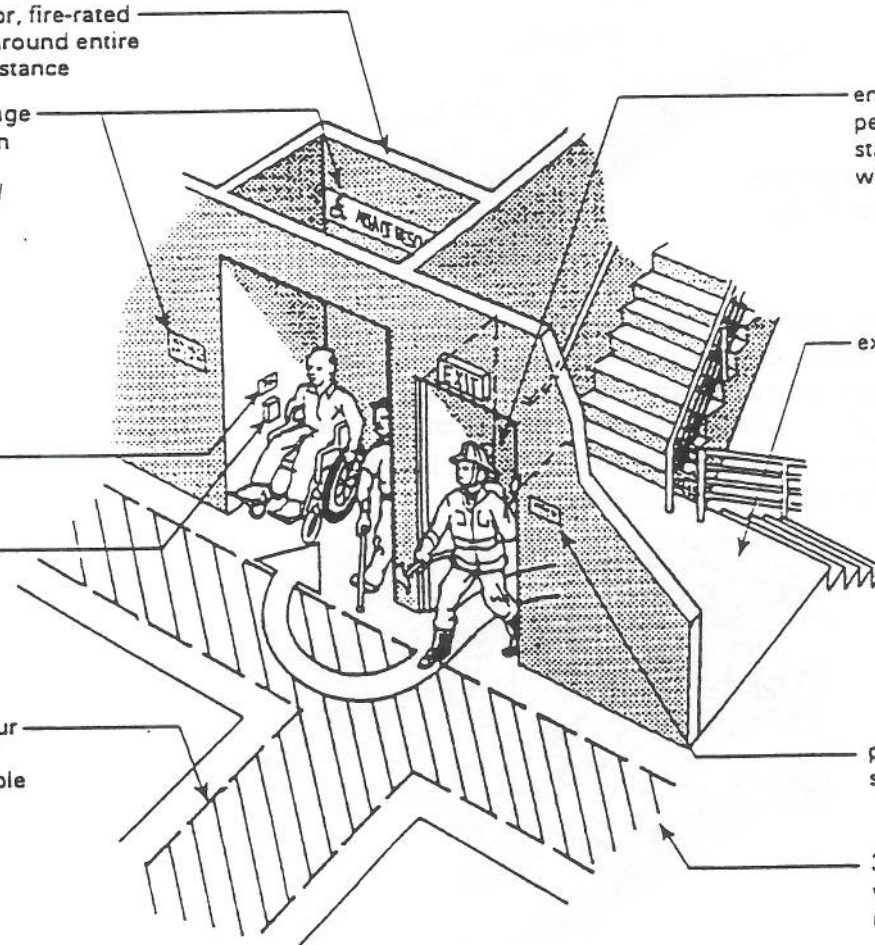

Area of Rescue Assistance Located Adjacent to Exit Stairwell

AREAS OF RESCUE ASSISTANCE

Location 1: Stairway Smokeproof Enclosure

Portions of stairway landings can be allocated as areas of rescue assistance when the stairway is within a smokeproof enclosure.

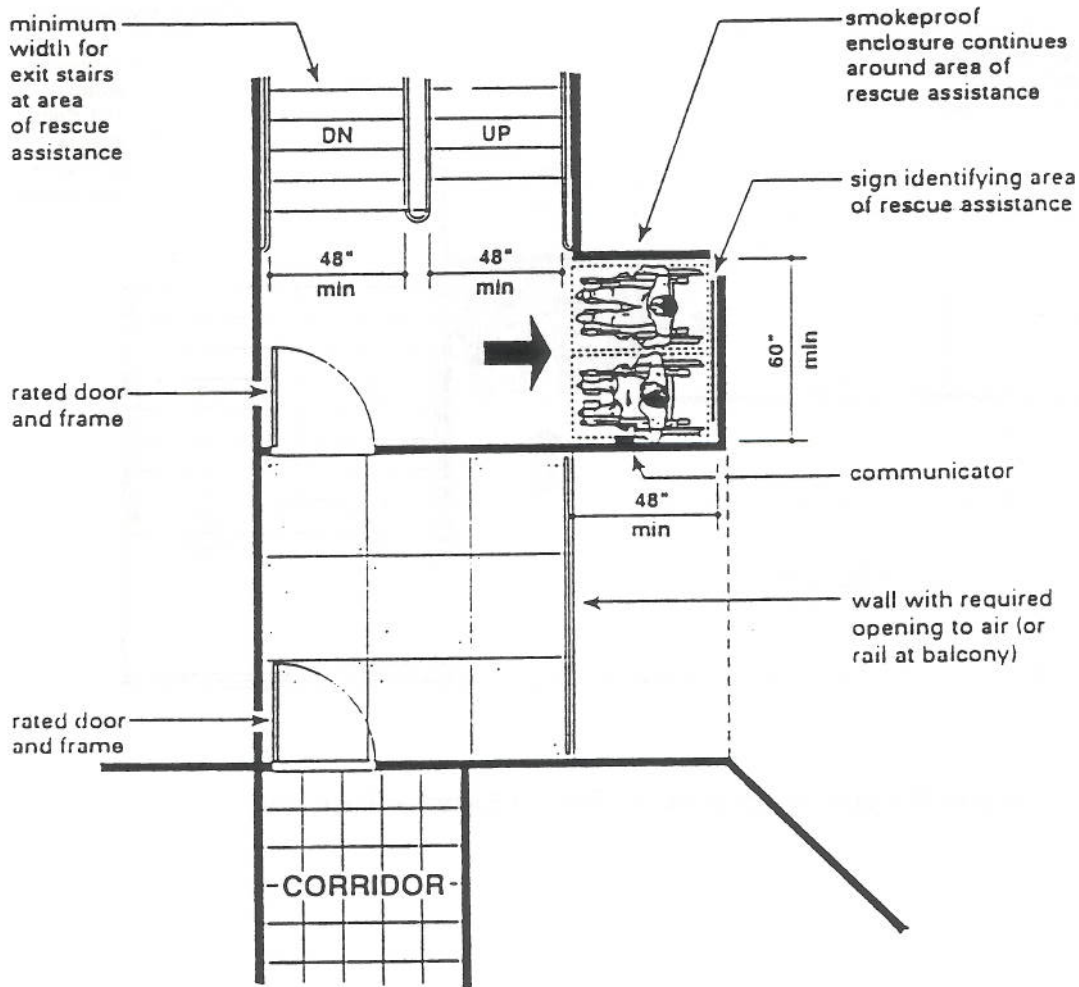

Area of Rescue Assistance in Smokeproof Enclosure

Location 2: Exterior Balcony

A portion of a balcony on the exterior of a building, adjacent to a stairway, can be designated as an area of rescue assistance. If there is an opening into the interior of the building within 20 feet it must have a three-fourths hour fire protection rating.

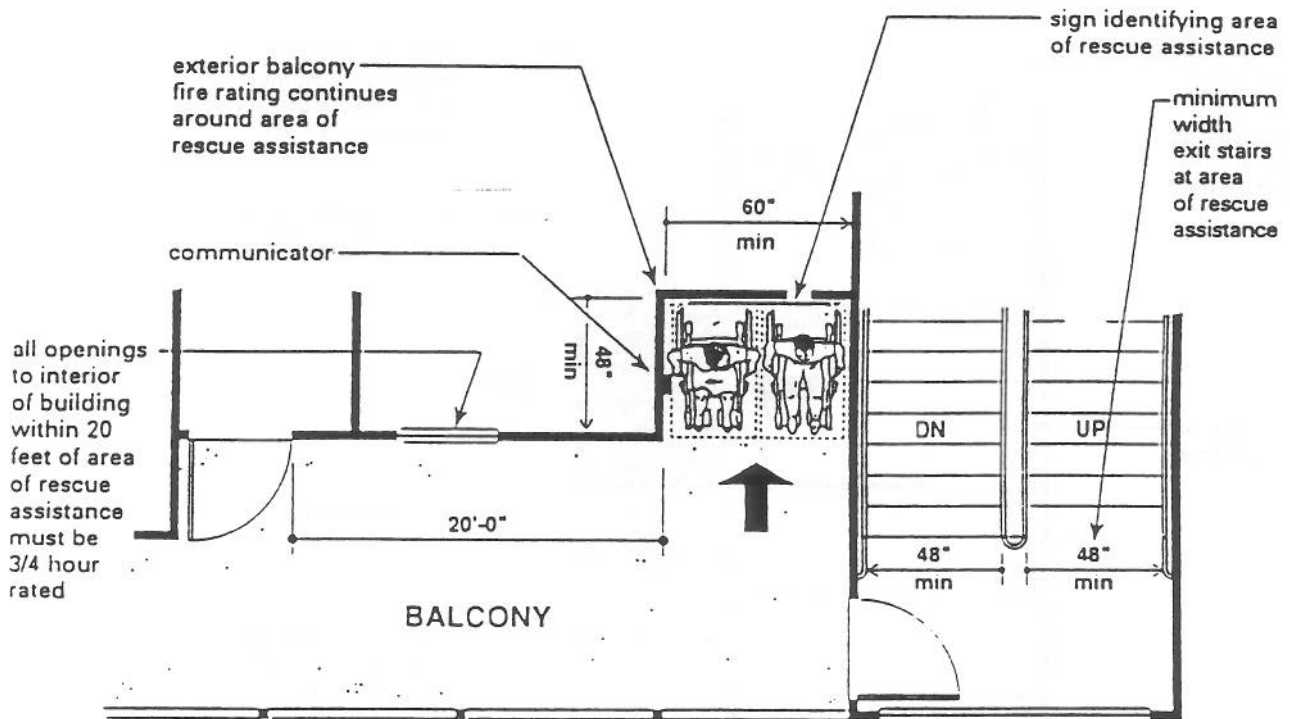

Area of Rescue Assistance as Part of Exterior Balcony

AREAS OF RESCUE ASSISTANCE

Location 3: Corridor

Areas of rescue assistance can be portions of a one-hour rated corridor located adjacent to the exit stair.

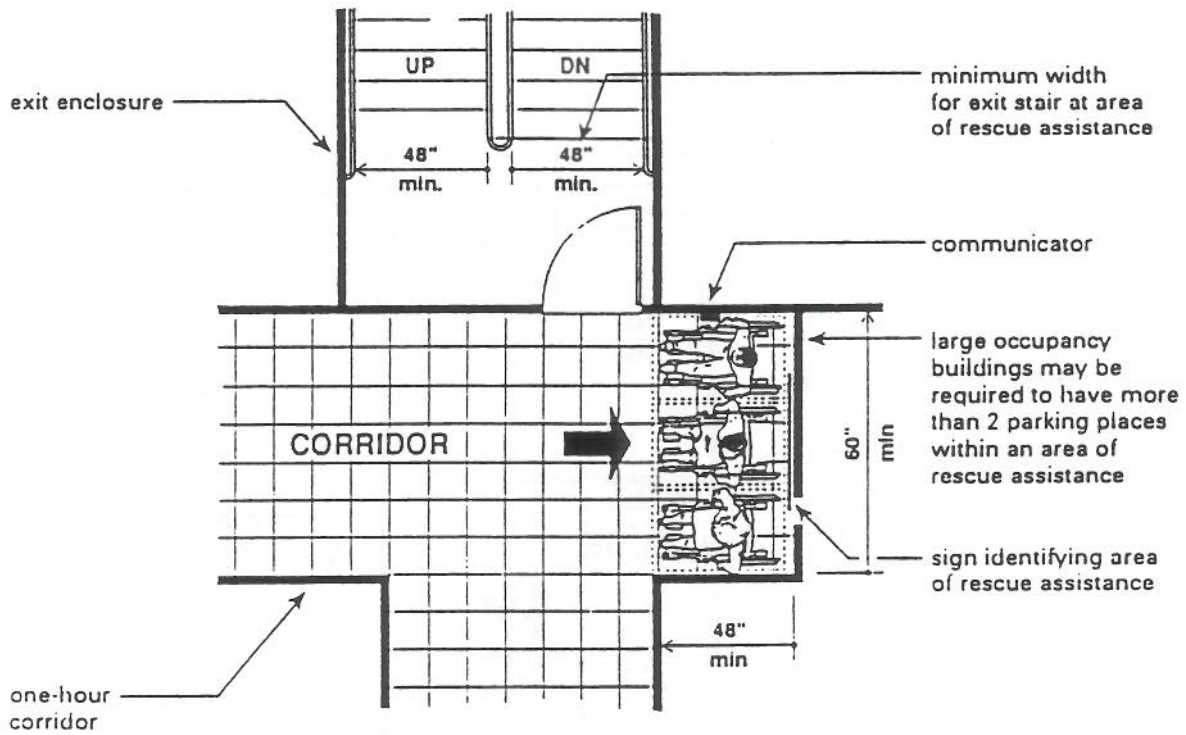

Area of Rescue Assistance
in One Hour Fire-Rated Corridor

Location 4: Vestibule

A vestibule between the corridor and the exit stair is another location that can be designated as an area of rescue assistance. The vestibule must have the same fire rating as the corridor.

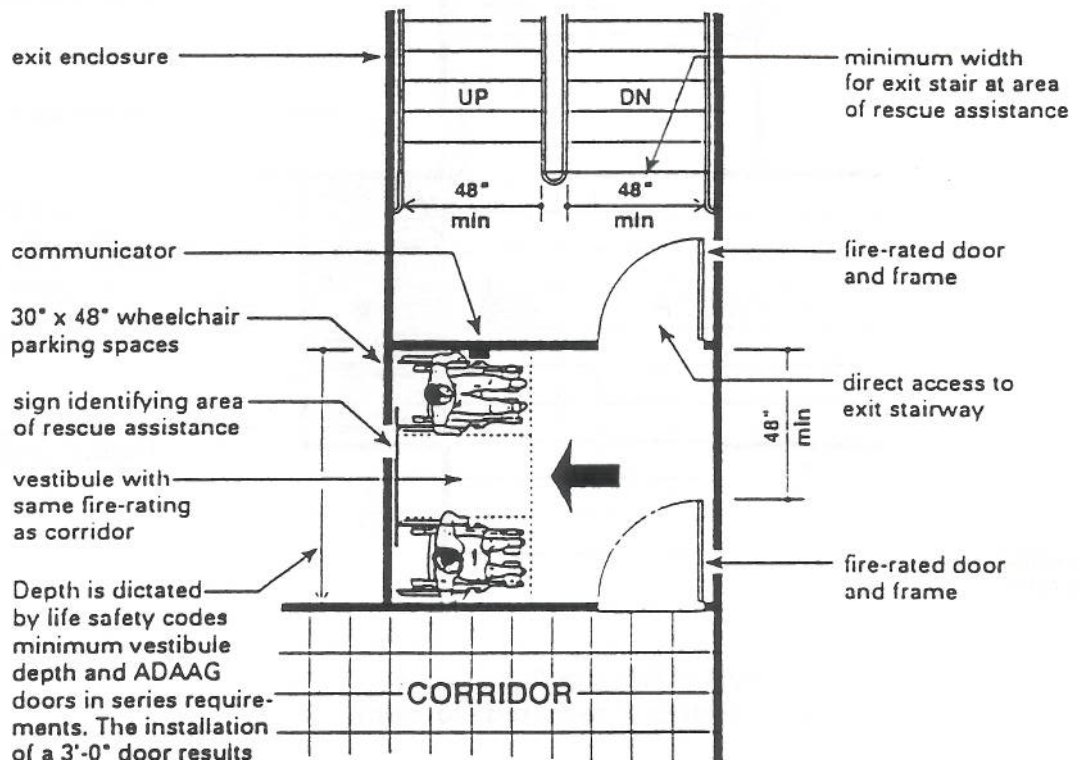

Depth is dictated by life safety codes minimum vestibule depth and ADAAG doors in series requirements. The installation of a 3'-0" door results in a vestibule depth of 84" minimum. If 6" is added to the vestibule it is possible to provide 3 parking spaces.

Area of Rescue Assistance in a Fire-Rated Vestibule

In some jurisdictions this vestibule may be required to be ventilated or pressurized.

AREAS OF RESCUE ASSISTANCE

Location 5: Vented Stairway Landing

A portion of a stairway landing can be an area of rescue assistance provided the presence of the wheelchair parking spaces does not interfere with the use of the stairway. The landing must be vented to the exterior of the building by natural or mechanical means and separated from the interior of the building by a one-hour rated door.

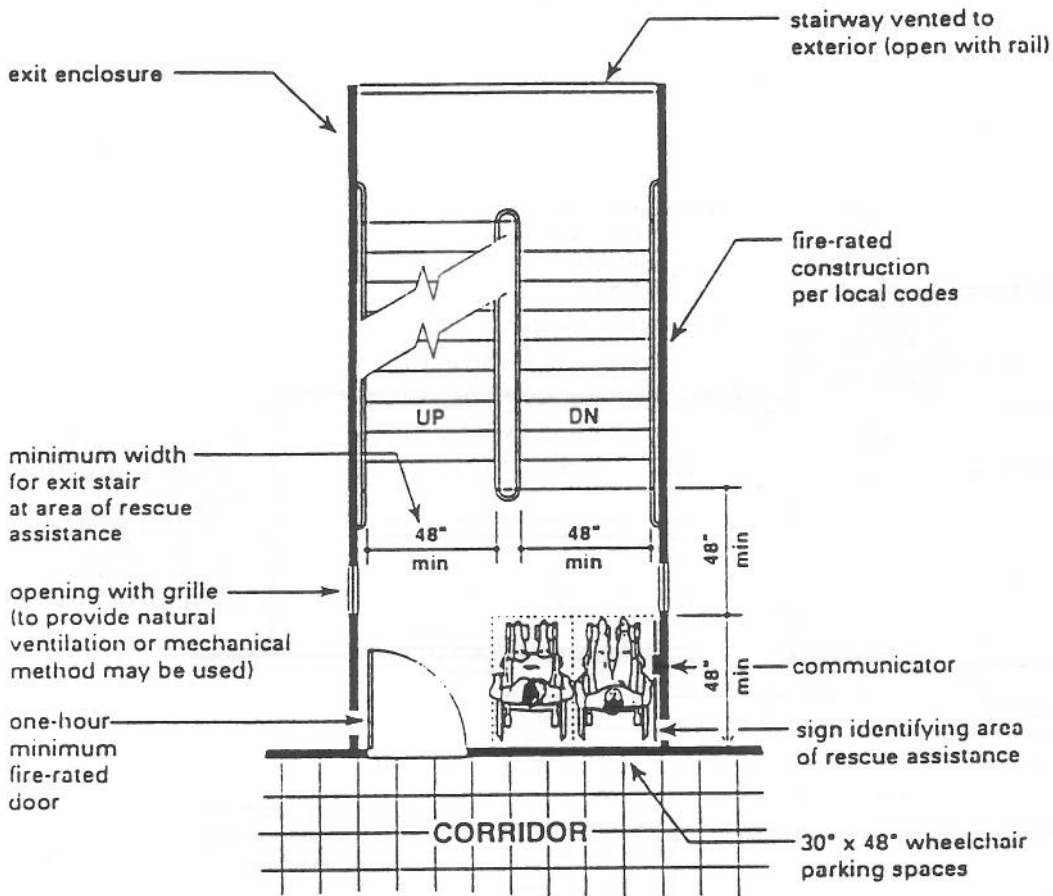

Area of Rescue Assistance in Vented Stair Landing

When the area of rescue assistance is located on the landing of the stair the usual building elements such as the fire extinguisher, sprinkler valve, and fire cabinet should not be placed in or protrude into the clear floor space required for wheelchair parking spaces.

Location 6: Adjacent Room

An area of rescue assistance can be a room that is separated from other portions of the building by smoke barriers of one-hour minimum construction. The room must have direct access to an exit enclosure (stairway). The doors to this room must have a minimum 20 minute fire rating, and be self-closing or automatic closing tight fitting smoke and draft control assemblies. If the adjacent stairway is required to have a rating greater than one hour, the area of rescue assistance and door ratings must be the same as the stairway.

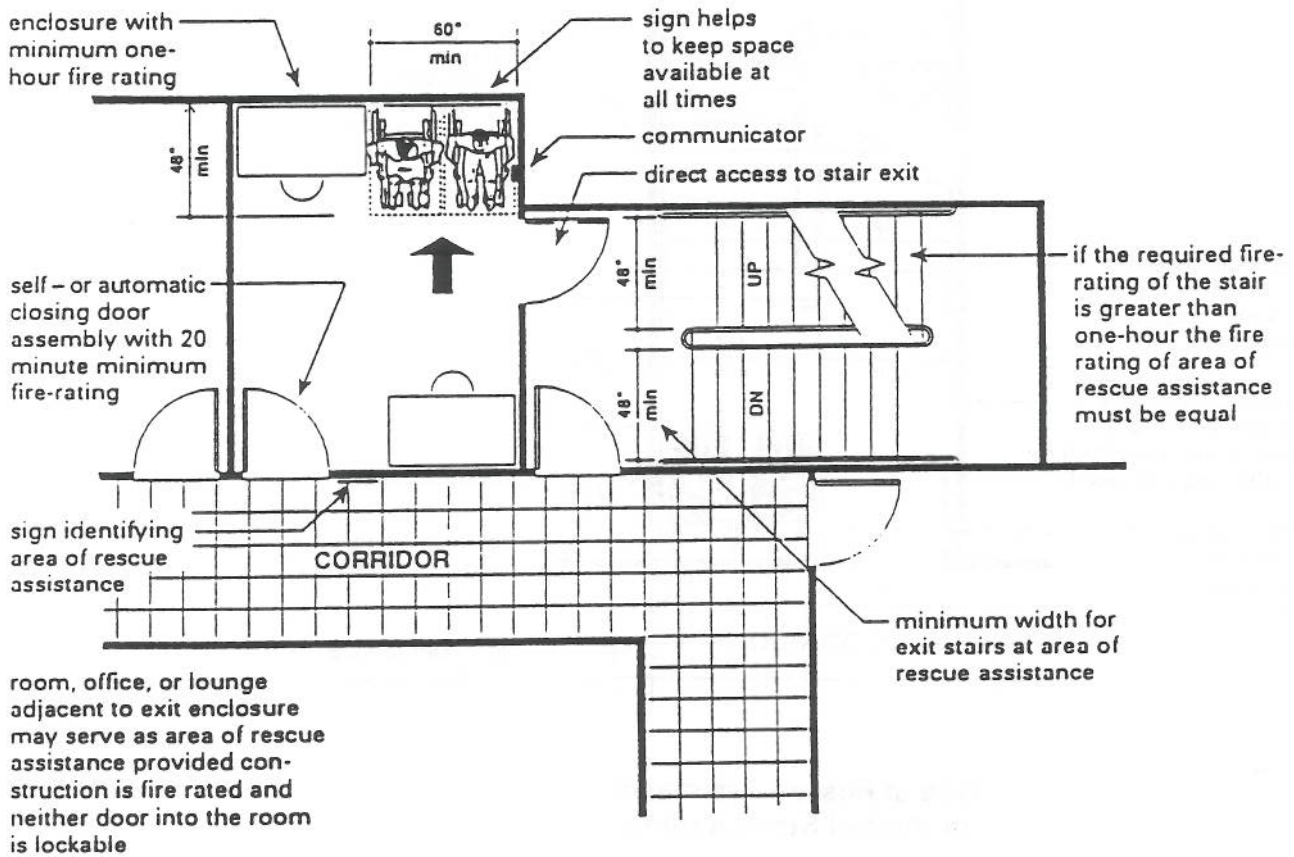

Area of Rescue Assistance Within an Adjacent Room

AREAS OF RESCUE ASSISTANCE

Location 7: Pressurized Elevator Lobby

Areas of rescue assistance can be portions of elevator lobbies when the lobby and elevator shafts are pressurized as required by local authorities for smokeproof enclosures and when all the requirements of the ADAAG for areas of rescue assistance are met. The pressurization system must be activated by smoke detectors located (as approved by the local authorities) on each floor of the building. The equipment necessary to pressurize the lobby and the elevator, including ductwork, must be separated from other portions and systems of the building by a minimum of two hour fire rated construction.

Notes in italic are recommendations.

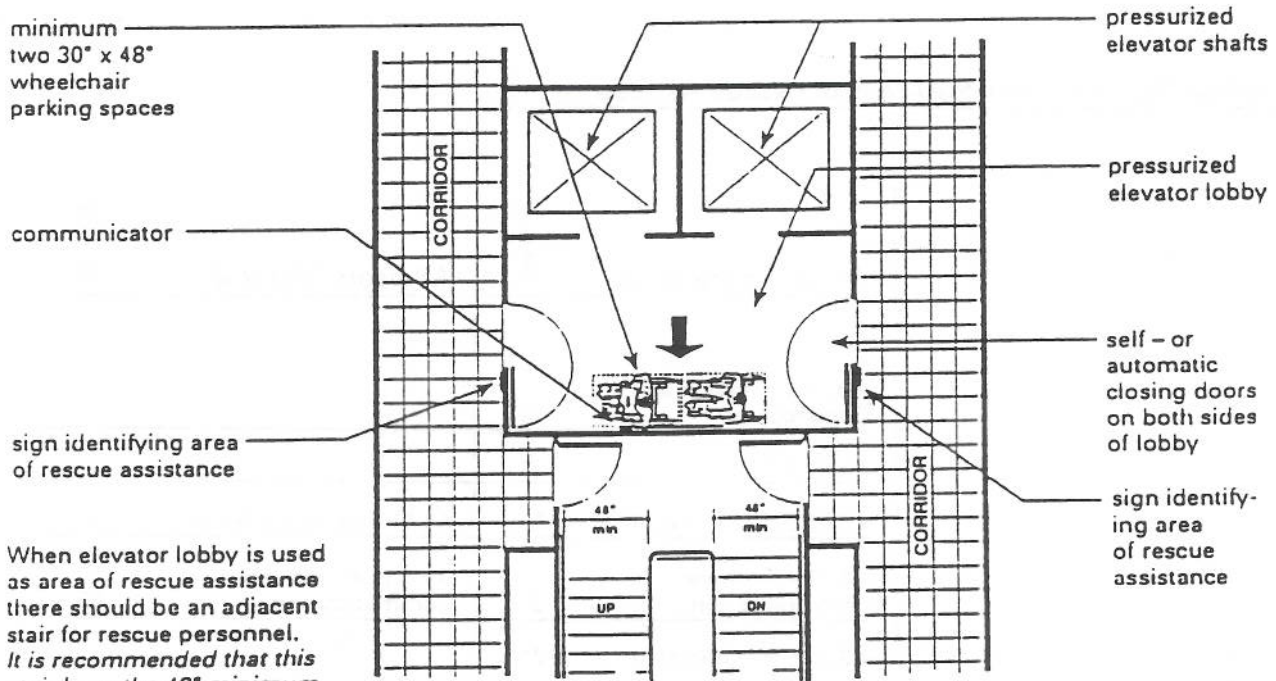

When elevator lobby is used as area of rescue assistance there should be an adjacent stair for rescue personnel. *It is recommended that this stair have the 48" minimum width for exit stairs at areas of rescue assistance.*

Area of Rescue Assistance Located in an Elevator Lobby

ADAAG Reference Index for Areas of Rescue Assistance

Scoping Requirements for Areas of Rescue Assistance

(Types of Facilities Covered,
Minimum Number, Location,
and Exceptions)

- 4.1.3 (9) Accessible Buildings:
New Construction
- 4.3.10 Egress (Accessible Route)

Technical Requirements for Areas of Rescue Assistance

Primary Reference	ADAAG Pg. #	Advisory Material	ADAAG Pg. #
4.3.11.1 Location and Construction	20		
4.3.11.2 Size	21		
4.11.3 Stairway Width	21	A4.11.3 Stairway Width	A4
4.3.11.4 Two-way Communication	21	A4.3.11.4 Two-way Communication	A5
4.3.11.5 Identification	21		

OUTLINE: AREA OF RESCUE ASSISTANCE SYSTEM

INTRODUCTION

HI-LITE AND REVIEW TECH SHEETS ADA ACCESSABILITY GUIDELINES

REVIEW (REPEAT) REQUIREMENT TO PROVIDE AUDIBLE & VISUAL TWO-WAY SIGNALLING TO/FROM AN AREA OF RESCUE ASSISTANCE.

REVIEW MANUFACTURER : CORNELL HAS BEEN A MANUFACTURER OF NURSE CALL SYSTEM FOR 25 PLUS YEARS AND A LEADER IN RESCUE ASSISTANCE COMMUNICATION SYSTEMS

MENTION YOUR POSITIVE REP EXPERIENCES WITH CORNELL HISTORY....SPECIAL EXPERIENCES...UNIQUE SALE ...ETC.

4200 SERIES DEMO

SET-UP: SEPARATE REMOTE STATION FROM MASTER BY 10/12'

DEMONSTRATE SIMPLICITY OF STATION // DEPRESS BUTTON POINT OUT AUDIBLE & VISUAL INDICATORS

DEMONSTRATE SIGNAL RESPONSE AT MASTER AND TWO-WAY AUDIBLE & VISUAL COMMUNICATION

DEMONSTRATE PUSH TO TALK VOICE PATH
NOTE: MASTER IS IN CONTROL OF COMMUNICATION (PEOPLE IN REMOTE RESCUE AREA MAY BE IN PANIC)

REPEAT DEMO (GET PARTICIPANTS INVOLVED)

PRODUCT BULLETIN SPECIFICATIONS: REVIEW BACK OF BULLETIN FOR SPECIFICATIONS...READ THEM TO AUDIENCE!

ASK FOR ANY QUESTIONS. IF UNABLE TO ANSWER / ADVISE FACTORY WILL GET BACK TO THEM.

CLOSE: SUMMARIZE THE AMERICAN DISABILITIES ACT IS A RESULT OF THE JUSTICE DEPARTMENT CIVIL RIGHTS LEGISLATION TO ENSURE SAFETY FOR THE DISABLED DURING AN EMERGENCY. MOST OF THE EXAMPLES RELATE TO FIRE BUT WEATHER, CIVIL DISTURBANCES AND UTILITY DISRUPTION CAN HAVE THE SAME EFFECT

THE N F P A AND ITS MEMBERS STRONGLY SUPPORT THE PROVISION FOR AREAS OF RESCUE AND COMMUNICATION SYSTEMS AS IT MINIMIZES RISK FOR PROFESSIONAL RESCUE PERSONNEL IN AN EMERGENCY.

These signs meet ADA specifications for use with Areas of Rescue Assistance.



SN -P42F



SN -P42R

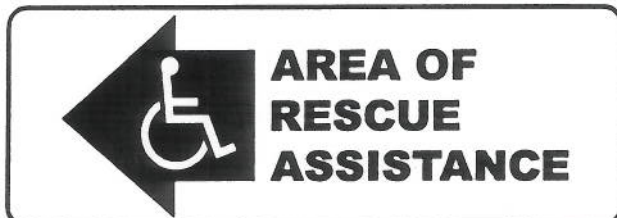

SN -P42L

Specifications SN-P Series

6" x 16", white PVC Plastic with blue lettering.
Mounted via double-faced tape (attached.)

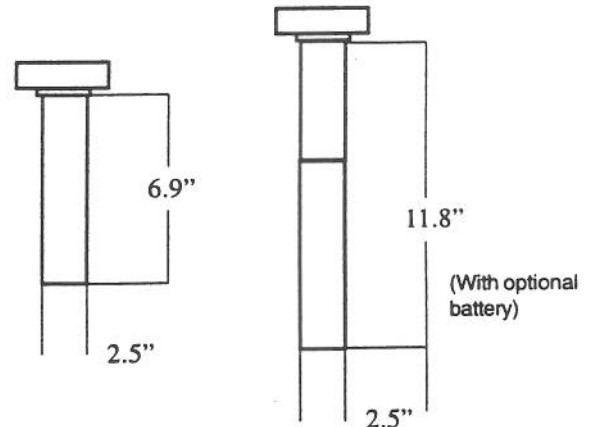

Specifications SN-E Series

120 or 277 VAC input capability. (2) 15 watt long life incandescent lamps.

Impact resistant UL 94 V-0 Thermoplastic in white.

Specifications SN-B Series

Same as SN-E above.

Battery powers (2) 4 volt 3.6 watt high lumen DC incandescent lamps in emergency mode.

Sealed maintenance free lead calcium battery with an expected life of up to five years.

Rescue Assistance Systems

Series 4200
Audio



CORNELL
Communication Solutions

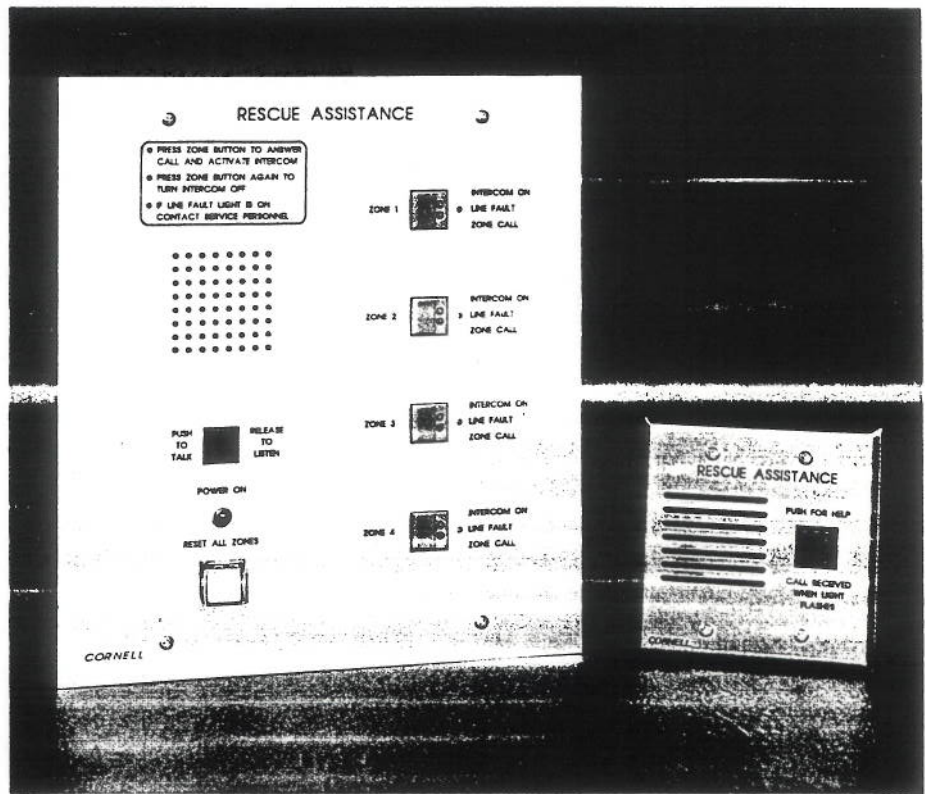

A Communication Need

As the percentage of elderly and handicapped people increases, the need for fully reliable rescue assistance communication has become essential. Many of these individuals wish to maintain an independent lifestyle, yet their potential need for rescue assistance is obvious and must be met.

The American Disabilities Act (ADA) now being enforced, requires a Rescue Assistance System in all newly constructed multi-story commercial buildings and public accommodations to provide a means to request evacuation assistance in emergencies. The ADA also applies to significant renovations of existing multi-story facilities.

The Complete Solution

The 4200 Series Audio Rescue Assistance System is an extension of the time proven CORNELL 4100 Rescue Assistance System that has received wide industry acceptance. The 4200 includes voice communication which is initiated by simply depressing the call station button transmitting the signal to a central annunciator panel. A single pulse tone and a flashing light signals the caller that the alarm has been received. The central station can then talk to the caller. The caller need not take any other action to communicate with the central station, an important feature when a caller is under stress in an emergency situation.

Versatile, Dependable

The central station operator on receiving a call station signal activates a zone button that illuminates both a flashing red LED and a green "voice" LED. By depressing and releasing the "talk" button, voice communication is established for as long as required. Upon completion, the appropriate zone button is depressed again however, the flashing red light continues. If more than one zone is signaling, the control station accepts the calls in the same manner.

When the emergency is resolved, the central station operator pushes a reset button that restores the entire system to stand-by status. In the event of a wiring fault, each annunciator zone button is equipped with a yellow LED that will illuminate and an alarm that will sound identifying the area requiring service.

Proven Experience

For over 25 years, CORNELL has served the communication requirements of the hospital, clinic, nursing home, retirement, education and business markets. The thousands of successful installations involved are your assurance that CORNELL is a quality, on-time delivery source for all of your communication solutions.

Customer Service Support

An experienced and technically qualified staff is available to assist in analyzing your application and installment requirements and identifying solutions that exactly match your needs. For immediate service call CORNELL at:

1-800-558-8957

Rescue Assistance Systems Series 4100 Visual



CORNELL
Communication Solutions

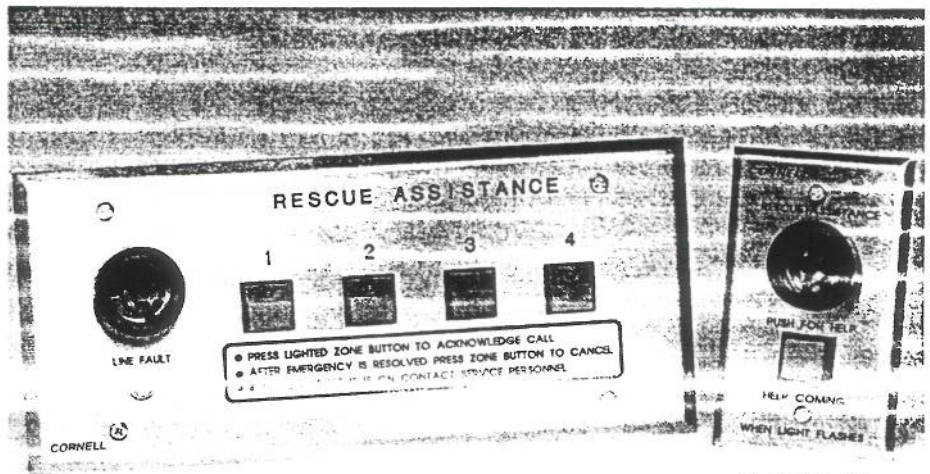

4 Zone Annunciator Panel

Call Station

A Communication Need

As the percentage of elderly and handicapped people increases, the need for fully reliable rescue assistance communication has become essential. Many of these individuals wish to maintain an independent lifestyle, yet their potential need for rescue assistance is obvious and must be met.

The American Disabilities Act (ADA) now being enforced, requires a Rescue Assistance System in all newly constructed multi-story commercial buildings and public accommodations to provide a means to request evacuation assistance in emergencies. The ADA also applies to significant renovations of existing multi-story facilities.

A Reassuring Solution

The cost effective solution is the CORNELL 4100 Rescue Assistance System which communicates the need for evacuation assistance. The 4100 provides a reliable repeating tone and light signal at the central station. When the alarm is acknowledged, the caller is signaled visually and audibly that help is on the way. When the emergency is resolved, the system is reset by pressing the acknowledgment button a second time. For additional safety, a line fault lamp will signal the central station if the wiring has been faulted.

Versatile, Economical

The economical 4100 System, which is designed for an unlimited number of zones or floor locations, is ruggedly constructed of stainless steel and anodized aluminum and emits a loud, clear tone that commands an immediate response. The bright, long-life LED indicator lights instantly identify the zone of need. When the control station is activated, a light and sound signal informs the caller that the request has been heard.

Proven Experience

For over 25 years, CORNELL has served the communication requirements of the hospital, clinic, nursing home, retirement, educational and business markets. The thousands of successful installations involved are your assurance that CORNELL is a quality, on-time delivery source for all of your communication solutions.

Customer Service Support

An experienced and technically qualified staff is available to assist you in analyzing your application and installation requirements and identifying solutions that exactly match your needs. For immediate service call CORNELL at:

1-800-558-8957

Communication Solutions **CORNELL**

CORNELL COMMUNICATIONS, INC. • 4911 West Good Hope Road • Milwaukee, WI 53223-4840
1-414-351-4660 • 1-800-558-8957 • Fax 1-414-351-4657

APPENDIX 4

Seattle Fire Department

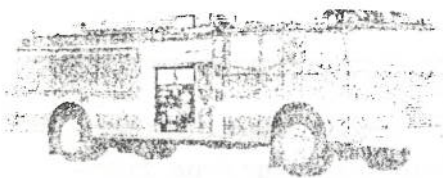

High Rise Building Fire Drills

May 1996

FIRE DRILL REQUIREMENTS

Building staff and occupants of high rise buildings are required to participate in fire drills a minimum of once every 120 days as specified in Section 19309.3 of the Seattle Fire Code. The drills should be conducted in accordance with the plan set forth in the building's Emergency Operations Plan approved by the Fire Department.

Exceptions: Jail inmates, hospital patients and occupants of apartment or residential condominium units, unless such occupants are also members of the high rise building staff.

A log book, indicating the date, time and section of the building in which the drill is conducted, should be kept to document compliance with the Fire Code requirement. Immediately prior to conducting the drill, notify your central station monitoring company that you are planning to have a drill. This will prevent a Fire Department response to your building. When the drill is completed, notify your monitoring company that you are now back to normal building operations.

PROCEDURES FOR CONDUCTING A DRILL

In a fire drill, building occupants should duplicate as closely as possible the actions they would take if a fire occurred. Total evacuation in high rise buildings is not practical in fire drills and could even be dangerous. Minimum participation would be to have building occupants go into the exit stairwell, although it is advisable to have them go to their actual staging area, if possible. Keep in mind that during an emergency, people tend to perform those behaviors that they have practiced.

Pre-plan escape routes from the floor and from the building. For those evacuating to the outside, locate an assembly area that is away from the building. This will allow for an accounting of the building occupants, as well as avoid congestion around the building.

ANNOUNCED VS. UNANNOUNCED

Fire drills may be preannounced to building staff or occupants, or they may be unannounced. Consideration of the building occupants and the use of the building may determine which type of drill is most appropriate. For example, in a residential building primarily occupied by older adults, or a mixed use facility where doctor's offices may be located, it may be best to notify occupants of the date and time of the drill. It may be appropriate to conduct an unannounced drill for only certain portions of the building.

(Over)

BUILDING STAFF PROCEDURES

In a drill, building staff, floor wardens and fire brigades should follow their procedures according to actions set forth in the building's Emergency Operations Plan. This is an excellent way in which to find out if the plan works smoothly and produces the desired results.

Critique your drill

Check for the following:

- Fire brigade members notified and responded appropriately to the fire floor.
- Building occupants could clearly hear and understand the alarm and any additional instructions.
- Evacuation completed in an orderly and expedient manner.
- Floor wardens guided occupants to safety, completed floor check and reported to building staff or Fire Safety Director upon completion of evacuation.
- Disabled persons assisted appropriately.
- Elevators not used for evacuation.

CONDUCTING DRILLS FOR PORTIONS OF YOUR BUILDING

It is not necessary to conduct a fire drill for an entire building at one time. If your building has a zoned fire alarm, in which the alarm may be heard in only portions of the building at one time, it will be easy for you to conduct a fire drill for a particular zoned area at one time.

If your building alarm is general and is heard throughout the building whenever it sounds,

you may still choose to conduct drills for portions of the building at one time. However, it may work best to conduct an entire building drill so you are not disturbing others each time the alarm sounds.

ESTABLISHING A FIRE SCENARIO

While evacuation of a high rise building may be completed in a matter of minutes in a fire drill, the situation is often quite different under actual conditions. Under fire conditions in a high rise building, it has taken as long as two to four hours to completely empty the building. Evacuation may be slowed by poor visibility from smoke, lighting failure, or because one or more of the exit stairwells is blocked by smoke or fire.

To prepare building occupants for more realistic conditions, you may choose to designate a specific location for the drill fire and establish a scenario which would alter the basic fire drill procedures. It is best to attempt this type of drill after occupants have become familiar with their standard evacuation procedures. This type of drill may be more interesting to building occupants, as they have to make decisions when they encounter situations apart from the ordinary.

Ideas for creating a fire scenario:

- Post signs or locate building staff inside one of the exit stairwells to inform those attempting to enter that the stairwell is blocked by smoke or flame and they must choose a different route.
- Designate individuals to wear signs indicating impaired sight, hearing or mobility which may require assistance from building occupants in an emergency. Other persons may be designated as non-English speaking and may require special instructions.

- Use a cardboard box decorated with red paper flames, or a flashing light, to indicate where the drill fire is located.
- Fire brigade members must locate the fire and determine if it is still small enough for them to extinguish. They should simulate extinguishment by identifying and locating the correct extinguishing equipment.

drill will be held at a convenient time, may yield better participation.

One employer in Seattle tries to make the drill a positive action for those participating by handing out candy to occupants as they leave the building to go to their assembly area. The occupants find the candy a pleasant surprise and it gives them something to talk about besides any inconvenience resulting from the interruption caused by the drill.

APATHY OR LACK OF PARTICIPATION IN FIRE DRILLS

There are some building occupants who continually refuse to participate in fire drills. Problems with frequent false alarms in a building may make matters even worse. In most instances, the Fire Department cannot issue citations for failure to participate in a drill. Some help may be provided by contacting the Public Education Section to see if it may be possible to schedule a fire safety meeting for building occupants. However, those who are unwilling to participate in a drill are generally unlikely to attend such a program.

The Fire Safety Director's best tactic in gaining cooperation in drills is to try to explain the advantages of participation. Explaining that under real fire conditions evacuation can be considerably more complicated is one method. Informing employers that liability for their employees increases if they do not allow or encourage participation in the drill may also influence them to participate. If a fire did occur and one of their employees was injured or killed, it is possible they may be named in some legal action because of their lack of support for learning fire safety procedures.

Making the drill more interesting by using a fire scenario, or checking to make sure the

FIRE DRILLS PAY OFF

Fire drills can make the difference in making sure occupants of your building will know what to do when a fire occurs. In spite of the investment incurred in installing alarm systems and other fire protection features for your building, if people do not act or know what to do, the protection features alone may not keep them safe. Regular fire drills are an integral part of your fire safety system. They pay off by making evacuation procedures work quickly and smoothly.

If you have questions about fire drills, contact the Seattle Fire Department Public Education Office at 386-1338.

Developing Your Own

FIRE Evacuation Plan

A Fire Evacuation Plan is a well thought out design that takes into consideration the unique features of your building and its occupants. No one plan will work for every building, but the main components are the same. Fire Department personnel are available to review your fire evacuation plan once it is completed.

Getting Started

Survey the building

Determine what types of fire and life safety systems are present - including fire alarm system, smoke detectors, voice alarm system, sprinklers, fire extinguishers, manual pull alarms, and fire doors. If your fire alarm system is monitored, be sure to keep the name and phone number of the monitoring company readily available at the fire alarm panel.

If you are not completely familiar with your fire alarm system or other fire protection features, contact your building management or a professional fire protection company to learn more about them.

Survey the building occupants

Does your building house a changing population, as in a retail store or restaurant, or will the building occupants be familiar with the facility? Note any special needs that individuals may have, such as non-English speaking or physical disabilities.

Developing A Plan

Develop a floor plan

Design a basic floor plan for each floor of the building. On each floor, indicate the location of all fire exits, manual pull stations, and extinguishing equipment. Post the floor plan throughout the building. Mark YOU ARE HERE according to the location of the posted plan. Then, mark the two closest fire exits. Also, note that elevators must not be used as a fire exit.

Develop written procedures

This can be a simple flyer that you distribute to tenants, or a bound document that details the roles of staff and tenants during a fire emergency. This document should be readily available for building occupants and distributed to new staff during orientation.

Assign a meeting place

Choose an outside location for occupants to meet after evacuating - at a distance from the building. In the event of an evacuation, this is a place to assemble and make a head count. The meeting place location should be far enough away from the building to keep individuals out of the way of fire fighting activities and away from falling glass and debris.

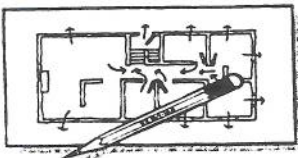

Implementing the Plan

Staff or resident meetings, new employee orientations, and building newsletters are effective ways of introducing tenants to a new Fire Evacuation Plan. Explain the routes of evacuation and point out alarms and extinguishing equipment. Let them know where the predetermined meeting place is for each floor or section of the building, if evacuated. Explain the proper procedures for reporting a fire. Stress that elevators cannot be used for evacuation in a fire emergency.

Recruit floor wardens

Floor wardens are volunteers selected from among the building staff and tenants whose role is to assist in the evacuation of occupants from the building in the event of a fire alarm. Floor wardens are on the front lines of emergency response when a fire occurs. They must be familiar with the building evacuation plan, and should receive training at least annually.

The Seattle Fire Department can provide assistance in training employees or residents. Contact the Public Education Section at 386-1338.

Reporting Emergencies

The spread of fire can be very fast. It takes less than three minutes for a free-burning fire to reach temperatures over 1,000 degrees F. Controlling the fire and evacuating every one safely depends on immediate notification of the emergency to the Fire Department and building security or management personnel.

Post all phones with the Fire Department's emergency number.

In Seattle, call 9-1-1 for Police, Fire or Medical Aid. Make sure the address of the building appears on the telephone. If the building manager wants to be notified, the appropriate number should also be listed on or near the phone.



Building occupants should be instructed to call 9-1-1 whenever an emergency occurs.

They should be prepared to state:

- The nature of the emergency.
- The address of the building.
- The nearest cross street.
- The extent of the fire and specific information, if known.

The caller should never hang up until told to do so by the emergency operator.

Automatic Fire Alarm Reporting

A common misconception is that building fire alarms are always monitored by the Fire Department. This is not true. Some building fire alarms are monitored by private monitoring companies. When such a company receives a signal indicating an alarm has activated, they in turn notify the appropriate fire department dispatch center. Never make the assumption that a fire alarm will automatically be reported to the Fire Department. **Always make sure that a call has been placed directly to 9-1-1** regardless of whether your building is monitored by a private monitoring service.

Fire Alarm Response Procedures



Treat every alarm as an emergency

In every instance, if an alarm sounds, all building staff and occupants should react as though it is a real emergency.

1. The Fire Safety Director, or responsible staff member, proceeds to the fire alarm panel. Initial evacuation begins immediately upon alarm.
2. Notify the Fire Department by calling 9-1-1.
3. If available, trained building staff members investigate to determine the location of the fire, and take steps to extinguish it if possible.
4. When the Fire Department arrives, the Officer in charge takes command at the scene.
5. If building staff determine that the alarm is false prior to the Fire Department's arrival, call 9-1-1 and relay the information to Fire Department dispatchers.
6. *Upon instruction of the fire dispatcher*, building personnel may silence the alarm. **DO NOT RESET THE ALARM!**
7. The Fire Department dispatcher will notify the fire companies in route to your building that a false alarm has been indicated. One fire company will continue to your building to verify that the alarm is false. All other fire department response will be cancelled.

It is extremely important not to reset the fire alarm when you believe an alarm is false, until directed to do so by the Fire Department. If the alarm is reset prior to Fire Department permission, it may be necessary for the Fire Department to search your building completely to verify the alarm is false.

Procedures for Persons Unable to Use Exit Stairs

If you can move to the exit and have persons to assist you

- Move to the exit stairwell. Wait until all persons on the floor have evacuated and traffic in the stairwell has cleared. If the stairwell is free of smoke, enter and wait on the stairwell landing. Two people should wait with you, while one person should inform the arriving Fire Department of your location. Make sure that the door is securely closed.
- Wait with your assistants for further instructions. The Fire Department will send fire fighters to assist you if evacuation is necessary.
- If you are waiting in the exit stairwell and traffic builds from the evacuation of upper floors, reenter your floor to allow others to pass and the stairwell to clear.
- If there are too many individuals to wait on the landing, an area of refuge should be sought on the floor, such as an apartment or a room with a door, window and telephone. Use the fire survival skills described below.
- Assistants should not attempt to carry you down the stairs unless conditions in the stairwell become threatening. If conditions deteriorate, the assistants can then perform a carry down the stairs to a safer area.

If you are unable to leave the floor

If you do not have persons to wait with you, or are unable to leave your unit, refuge should be sought on the floor. Most appropriate would be a totally enclosed room with a telephone and window. This may be your apartment, or an office.



Observe the following survival rules:

- Use towels or clothing to block openings around doors or vents where smoke might enter. Put a wet cloth over your mouth or nose.
- Place a signal in the window. The signal can be anything that will call attention to your location. For instance, tie the curtains in a knot.
- If smoke or fire enters your unit, call 9-1-1 to report your location. Stay low to the floor to breathe the best air.
- It is advisable not to open or break windows. Often smoke from the outside of the building can enter through open windows. Breaking windows will put you at great risk to smoke entering from the outside, and will hamper rescue efforts below.

Fire Drills

In a fire drill, building occupants should duplicate as closely as possible the actions they would take if a fire occurred. A log book, indicating the date, time and section of the building in which the drill is conducted, should be kept. If your building fire alarm is monitored, notify the monitoring company of the drill immediately prior to its occurrence. There is no need to notify the Fire Department.

Fire drills may be preannounced to building staff or occupants, or they may be unannounced. Consideration of the building occupants and the use of the building may determine which type of drill is most appropriate.

Critique your drill

Check for the following:

- ✓ Fire brigade members (if present in your facility) notified and responded appropriately to the fire floor.
- ✓ Building occupants could clearly hear and understand the alarm and any additional instructions.
- ✓ Evacuation completed in an orderly and expedient manner.
- ✓ Floor wardens guided occupants to safety, completed floor check and reported to building staff or Fire Safety Director upon completion of evacuation.
- ✓ Disabled persons assisted appropriately.
- ✓ Elevators not used for evacuation.

Establishing a fire scenario

You may choose to designate a specific location for the drill "fire", and establish a scenario which would alter the basic fire drill procedures. It is best to attempt this type of drill after occupants have become familiar with their standard evacuation procedures. This type of drill may be more interesting to building occupants, as they have to make decisions when they encounter situations apart from the ordinary.

Ideas for fire scenarios:

- Post signs or locate building staff inside one of the exit stairwells to inform those attempting to enter that the stairwell is blocked by smoke and they must choose a different route.
- Use a cardboard box decorated with red paper flames, or a flashing light, to indicate where the drill "fire" is located. Have the staff person discovering it show you the correct procedure to follow.

Apathy or lack of participation in fire drills

You may encounter some building occupants who refuse to participate in fire drills. Problems with frequent alarms in a building may make matters even worse.

Your best tactic in gaining cooperation in drills is to try to explain the advantages of participation. Explain that under real fire conditions, evacuation can be considerably more complicated. Informing employers that liability for their employees increases if they do not allow or encourage participation in the drill may also influence them to participate. If a fire did occur and one of their employees was injured or killed, it is possible they may be named in some legal action because of their lack of support for learning fire safety procedures.

Making the drill more interesting by using a fire scenario, or checking to make sure the drill will be held at a convenient time, may yield better participation. Some buildings hand out candy to occupants as they leave the building to go to their meeting place, to provide an obvious incentive.

High Rise Buildings

Under the Seattle Fire Code, high rise buildings are required to submit a detailed Emergency Operations Plan to the Seattle Fire Department. A high rise building is classified as any building that has occupied floors 75 feet or higher above Fire Department access.

For additional information on developing or revising a high rise EOP, call the Public Education Section at 386-1338.

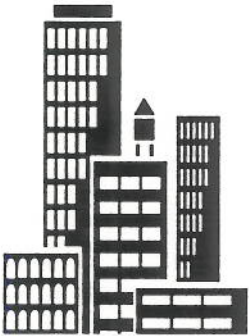

Additional Resources

The Public Education Section of the Fire Prevention Division provides assistance in evacuation planning, as well as resources for training staff and building residents. Call the Public Education Office during business hours at 386-1338 for further information.



A residential fire occurs every half hour in Ohio. How safe is your home from fire? To determine the safety of your home from fire hazards, study these questions with your family. Every "yes" answer indicates a positive fire safety situation. However, every "no" answer points to a fire hazard that needs to be corrected.

Matches and Careless Smoking Hazards _____ **Yes No**

- Do you keep matches away from sources of heat? Yes No
- Do you make sure matches and smoking materials are out before disposing of them? Yes No
- Do you have plenty of large, noncombustible ash trays in every room? Yes No
- Is "No Smoking in Bed" a rule in your home? Yes No

Electrical Hazards _____

- Do you have qualified electricians install or extend your wiring? Yes No
- When you buy electrical equipment and appliances, do you always look for the UL label of Underwriters' Laboratories, Inc.? Yes No
- Are there enough electrical outlets in every room to avoid the need for multiple attachment plugs and long extension cords? Yes No
- Are there proper heat controls on your electrical iron and all electrical appliances used for cooking? Yes No
- Do you have special circuits for heavy duty appliances? Yes No
- Do you use only 15 amp. fuses for your household lighting circuits? Yes No
- Are all extension cords of the right size, in the open and not under rugs or through partitions or openings? Yes No

Housekeeping Hazards _____ **Yes No**

- Do you keep your basement, closets and attic clear of rags, papers and other combustible materials? Yes No
- After using oily polishing rags, do you destroy them or place them in covered metal cans? Yes No
- If you store paint, varnish, and other items, do you keep the containers tightly closed? Yes No
- Has everyone in your family been warned never to use gasoline or other flammable liquids for cleaning clothes, furnishings or floors? Yes No

Heating and Cooking Hazards _____

- If you use oil heat or gas heat, is the equipment listed by the proper laboratories such as UL or the American Gas Association? Yes No
- Before the heating season begins, do you have your heating system inspected and serviced? Yes No
- If you have a wood burning stove, has it been installed properly according to manufacturers instructions? Yes No
- Do you burn seasoned wood and is it stored in the proper place? Yes No
- Are all vent connectors and flue pipes that pass through attics, floors, ceilings and walls properly installed? Yes No
- Is your kitchen stove, including the oven and the broiler, kept clean of grease? Yes No

(over)

Heating and Cooking Hazards (continued)

Yes No

- Do all portable heaters in your home bear the label of Underwriters' Laboratories (UL) or some other recognized safety testing agency?
- If you use a portable heater, is it placed well away from any and all combustible materials?
- Do you always refill the fuel tank of your kerosene heater outdoors?
- Since portable kerosene heaters use up oxygen when they burn, do you always have adequate ventilation?
- Do you always turn off the portable heater when you go to bed?
- Do you make sure that the fuel is not contaminated prior to using it in your kerosene heater?
- Is your inside basement door at the head of the stairs properly fitted and kept closed at night?
- Has everyone in the family been warned never to use any flammable liquids to start a fire in the stove, fireplace or furnace?
- Is every fireplace equipped with a sturdy metal fire screen?

Yard and Garage Hazards

- Do you keep your yard cleaned of leaves, debris and combustible rubbish?
- If you keep gasoline for use in a power mower or outboard motor, is it stored in a strong, clearly labeled red gasoline safety-type can?
- If your garage is attached to the house, is it separated by a fire-rated door which is kept closed?
- If you store kerosene, is it placed in an approved blue and white container that is clearly labeled kerosene?

Especially for Parents

Yes No

- Do you keep matches out of the reach of children?
- Do you leave a responsible person with your children when you go out, even for a little while?
- When you employ babysitters, do you instruct them carefully on what to do in case of a fire?
- Are you careful never to leave children alone in a room with a portable heater or wood stove?
- IMPORTANT: A child learns by example as well as by instruction. In regard to fire safety, do you always set a good example?

In Case of Fire

- Do you know the telephone number of your fire department?
- Do you know how to turn in a fire alarm?
- Do you have an escape plan with at least two ways out of every room in your home?
- Have you practiced that escape plan by holding fire drills in your home?

Smoke Detectors

- Do you have a smoke detector installed on every level of your home?
- Do you test your detector weekly to insure that it is in proper working order?



Printed and distributed by:
STATE OF OHIO
Department of Commerce
Division of State Fire Marshal
8895 E. Main St. Reynoldsburg, Ohio 43068
(614) 752-7115